

So You Want To Build A Play Hive?

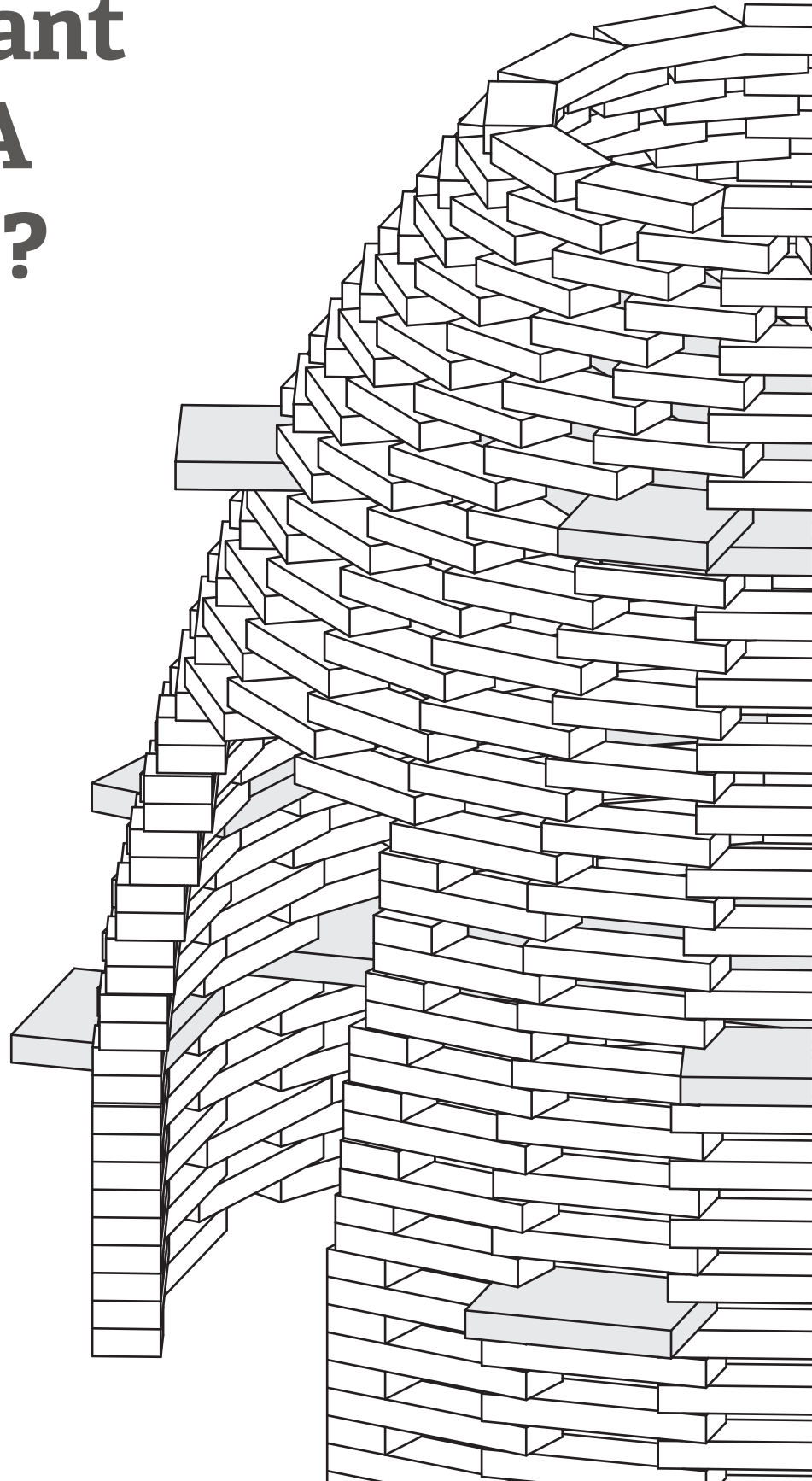

Welcome!

Now you're on your way to a fun little playscape for your children. It's compact, durable, and only needs a few simple tools to assemble. Don't be alarmed by the instructions; they're mostly pictures and templates. They don't bite. Just familiarize yourself with them, gather up your supplies, set aside a weekend or two, and soon you'll have a Play Hive of your own.

Materials

2 x 4 x 8' Lumber*	50
2 x 12 x 8' Lumber*	6
2" Screws	Many
Paint/Stain, in your favorite color	Optional

*The choice of lumber is up to you. Cedar and Pine are the most common choices. Cedar is more durable and lasts longer untreated, while pine is cheaper and can be treated.

Tools

Miter Saw or Circular Saw



To cut the blocks

Sander or Router



To smooth the edges

Drill or Impact Driver



To screw it together

Tape Measure

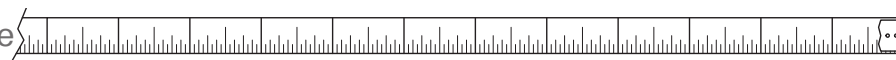

Pencil, Nail, String



To draw a big circle

Mask, Goggles, Hearing Protection

Anytime you're cutting wood

How It Works

The Play Hive is made up of layers of successively shorter 2x4s. Here's a list of the different sizes:

Length	Qty.	Layers
12"	84	1-8
11"	81	9-16
10"	82	17-24
9"	95	25-32
8"	68	33-38
7"	72	39-44
4"	24	1-23

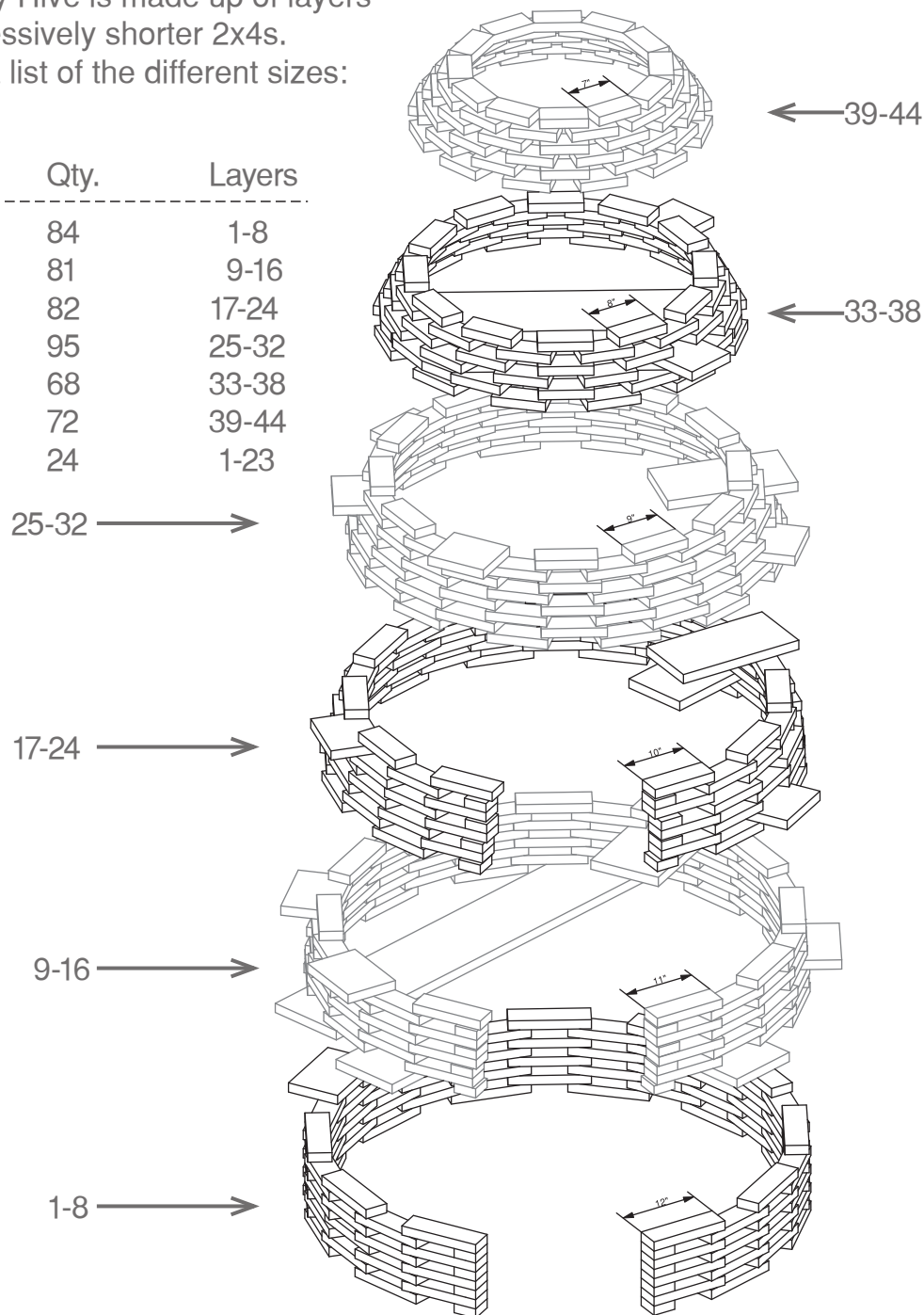

More Pieces

There's also some special pieces. These will be cut from 2x12s. Inside the hive there is a bench, a viewing platform, and steps. The shapes for the inside pieces are lots of different sizes, so we drew them out instead.

On the inside there's a bench, a spiral staircase, and a viewing platform. We've written out the sizes on the next page.

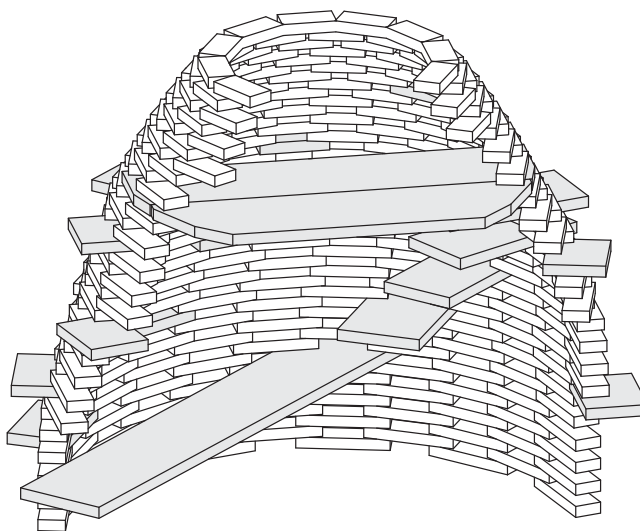

To make the Play Hive even more interesting, we've also added some steps/handholds on the outside. We haven't given these specific sizes or locations, since they can replace any of the regular 2x4 blocks. Just cut a few 2x12's into blocks of whatever size you think best and sprinkle them in during construction. We think 9" steps work best for small hands.

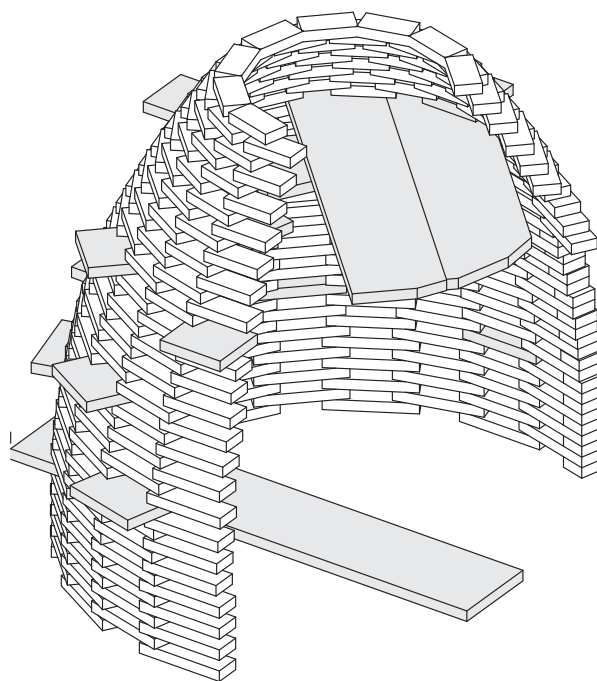

Cutting the Wood

Now its time to cut wood. Using the list from the previous page, cut all of the 2x4s to the appropriate lengths. Be sure to keep the parts organized. There might be some leftovers. Good!

Next come the steps and benches. Its important to cut these in the right orientation. Wood is much stronger supporting loads perpendicular to the grain than parallel. Cutting along the grain is called Ripping. Cutting across is called Cross Cutting. For simplicity, this project won't require ripping.

Part	Layer	Length
Bench	9	5'8"
Step 1	14	20"
Step 2	19	20"
Step 3	24	20"
Step 4	29	20"
Platform 1	34	44"
Platform 2	34	4'1"

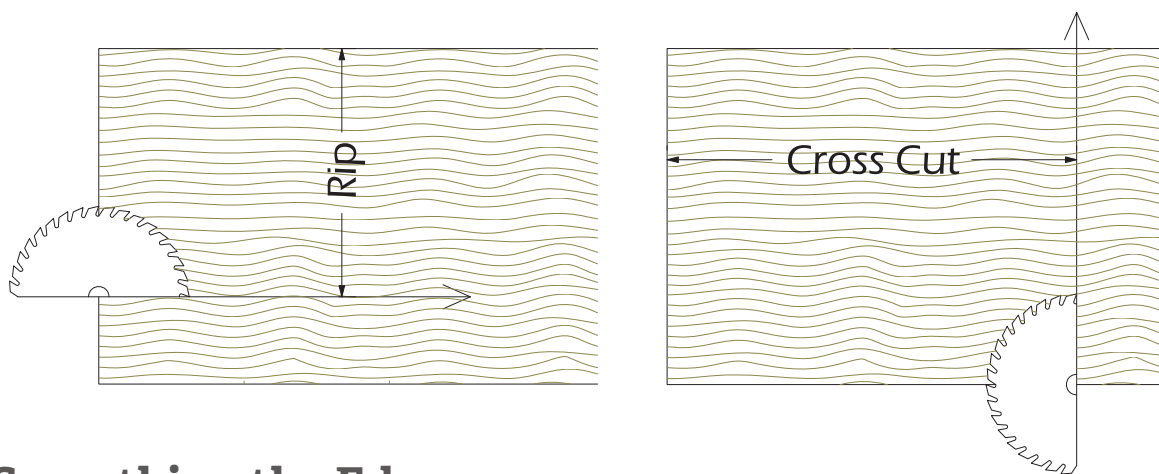
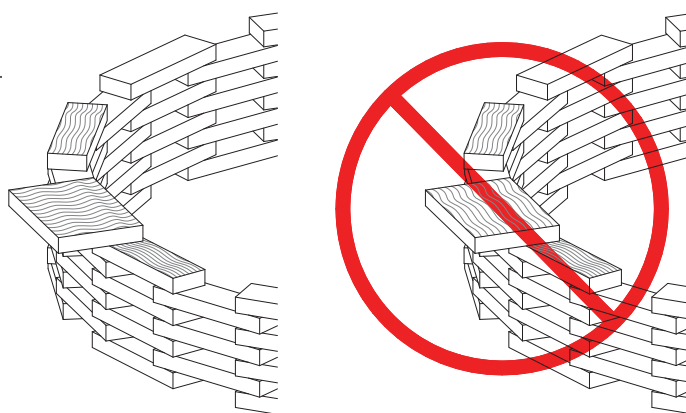

Smoothing the Edges

Finally, using a router or sander, round over the edges of the blocks. This will help prevent cuts and splinters. We don't recommend hand sanding because there are so many blocks.

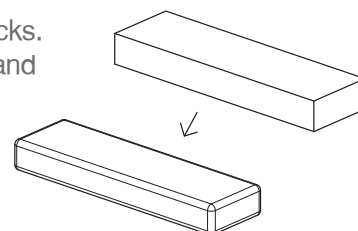

Laying It Out

Find somewhere you can draw a six-foot circle, be it two sheets of plywood, a lot of butcher paper, or a big sandbox. This will be the base of the Play Hive.

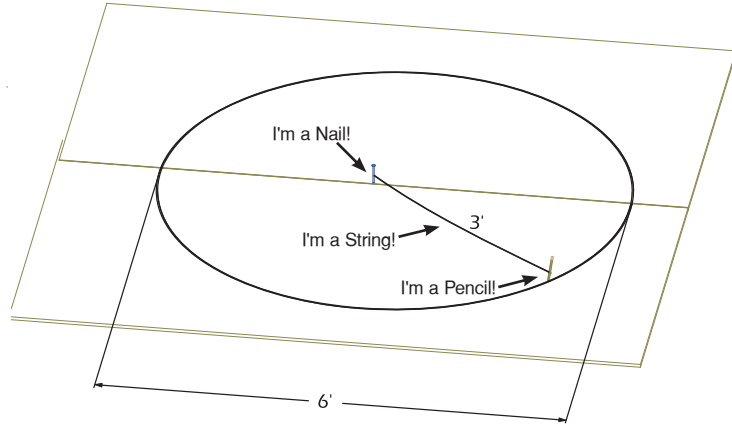

Place the 12" blocks at equal intervals around the circle. When you get to the entrance, pretend those small blocks are at the edges of a pair of invisible regular-sized ones. This is how the bottom ring of the Play Hive will look →

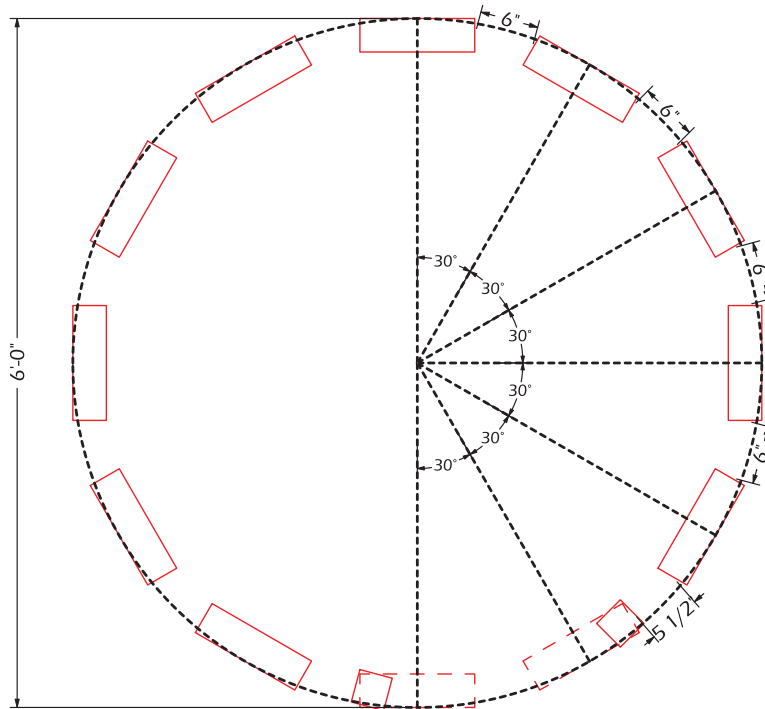

Building It Up

Finally, yes yes, its time to put all the pieces together. Since each layer is slightly different from the one below it, we've supplied all the templates to properly lay the layers out. Cut out the templates from the following pages, and then use them to align the blocks before screwing them in. Simply place the edge with the arrow against the outside edge of the block, center it, and put two screws into the end of each block. (That's four total.)

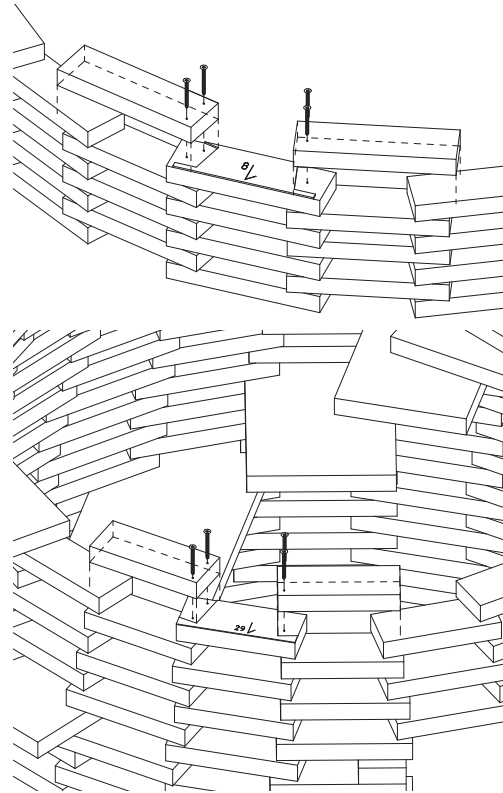

As you're building up, don't forget to put in the 2x12s. Here's a diagram of how the interior steps go

The outside steps are a little more freeform. If you're building up the Play Hive in slices (more about that on the next page), be sure to not put the steps at the top of the slice; leave a layer or two of 2x4 blocks above to firmly support the step.

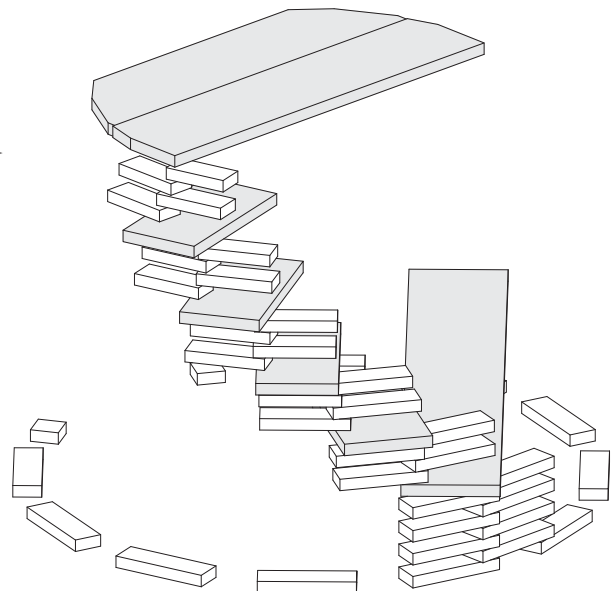

Finishing Touches

When we built ours, we painted the 2x12 blocks a different color. We invite you to try different color combinations to truly spice up your creation. You'll need buckets of paint and time to get dark colors, but fortunately for you pastels are "in" this year anyways.

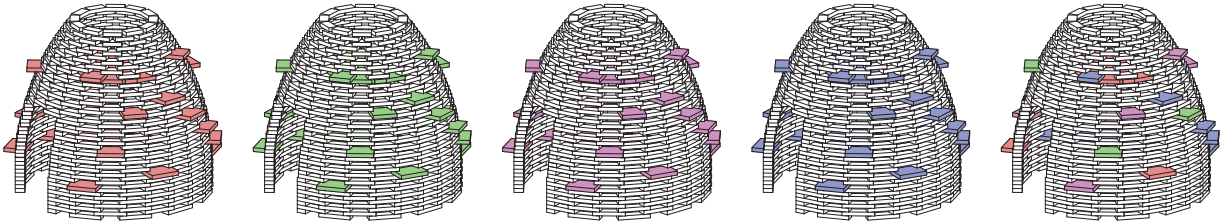

If you plan on moving the Play Hive, whether tomorrow or in a year, you'll find it helpful to assemble it in removable layers. Every 6-10 layers, skip screwing the blocks into the layer below. It'll look a bit like the diagram under the "How it Works" section.

When you have all the layers assembled separately, put them on top of each other, and put 8-10 screws into each joint. Voila! A finished Play Hive!

Let us know how you got on by sending us an email to:
lucy@thoughtbarn.com

The Beehive Playscape by Thoughtbarn is licensed under a Creative Commons Attribution-NonCommercial-ShareAlike 3.0 Unported License.

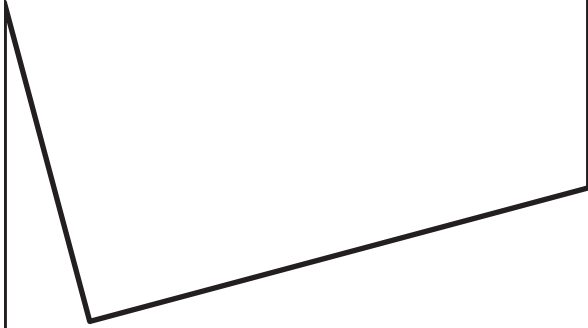

1-7

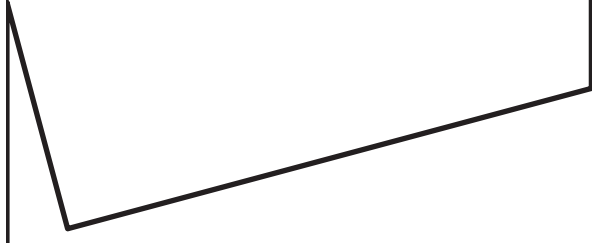
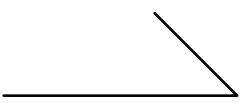

8

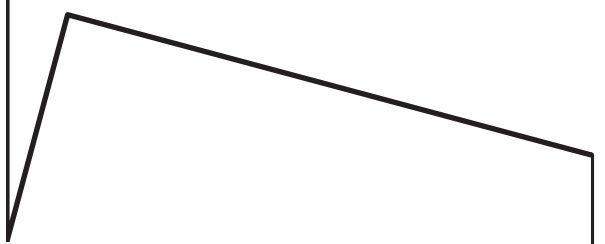
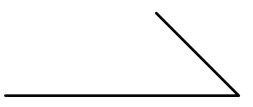

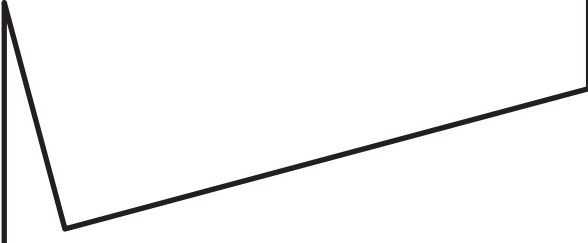

9

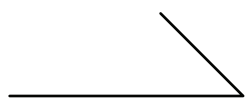

10

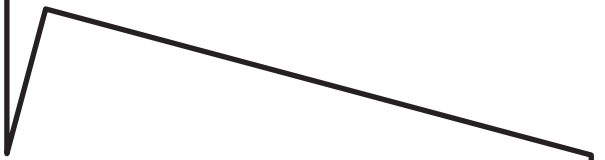
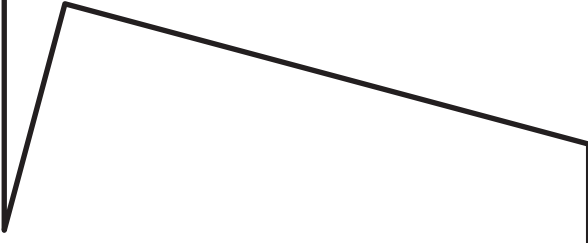
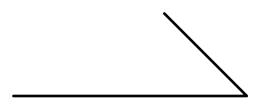

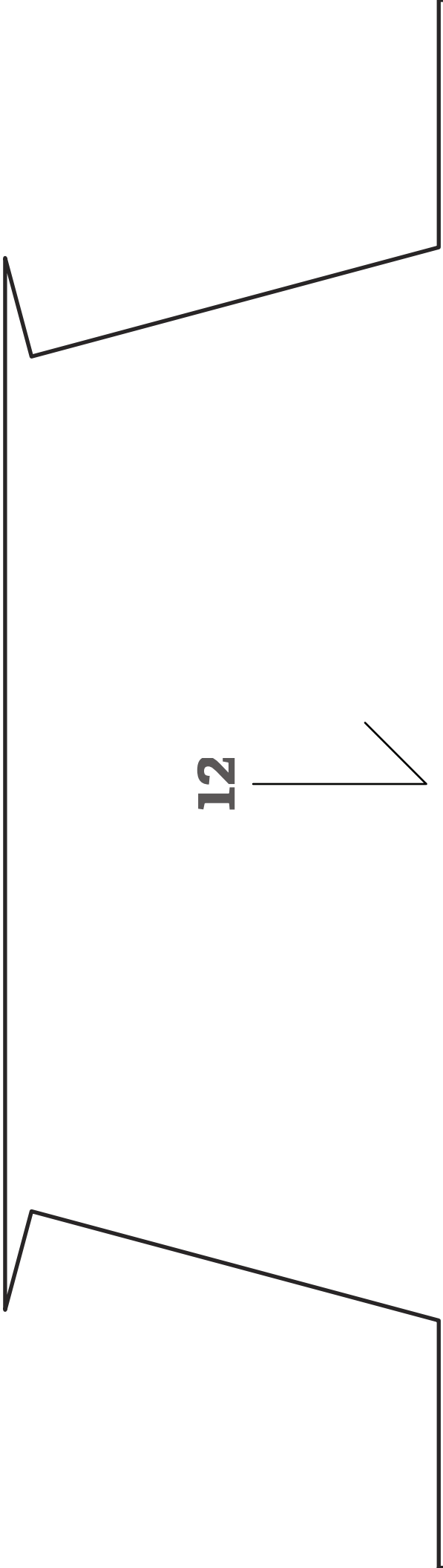
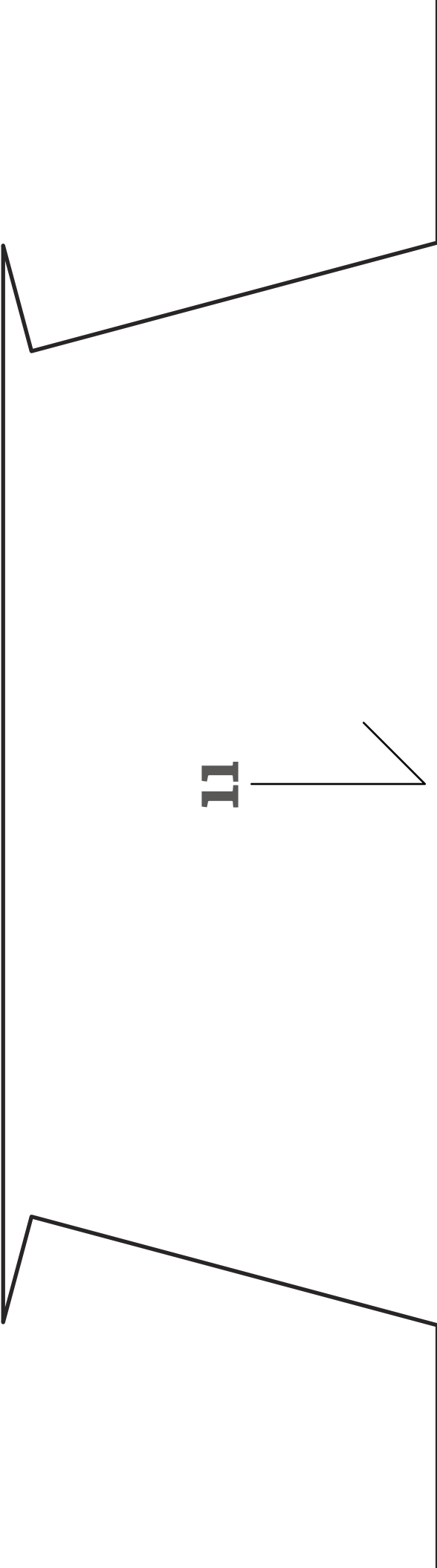

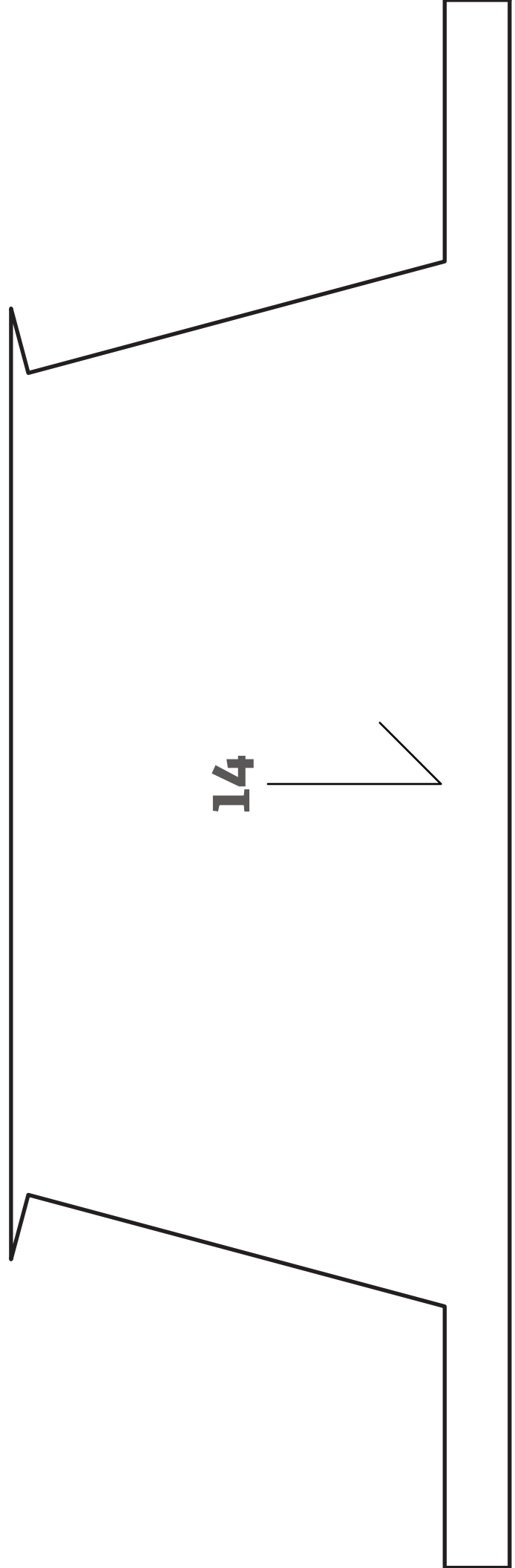
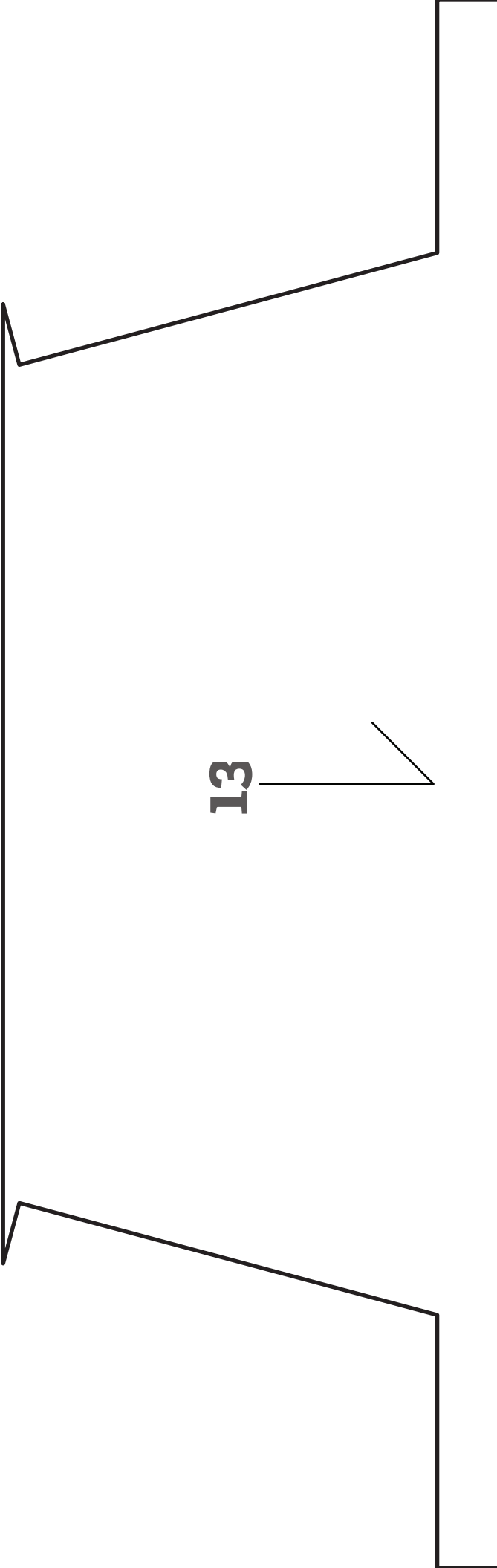

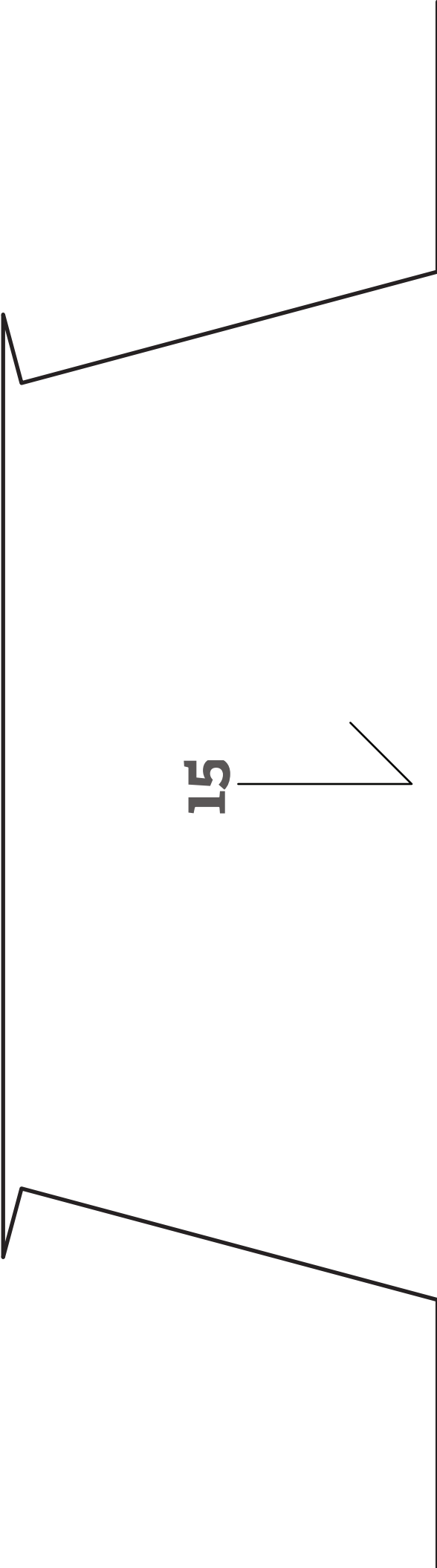

15

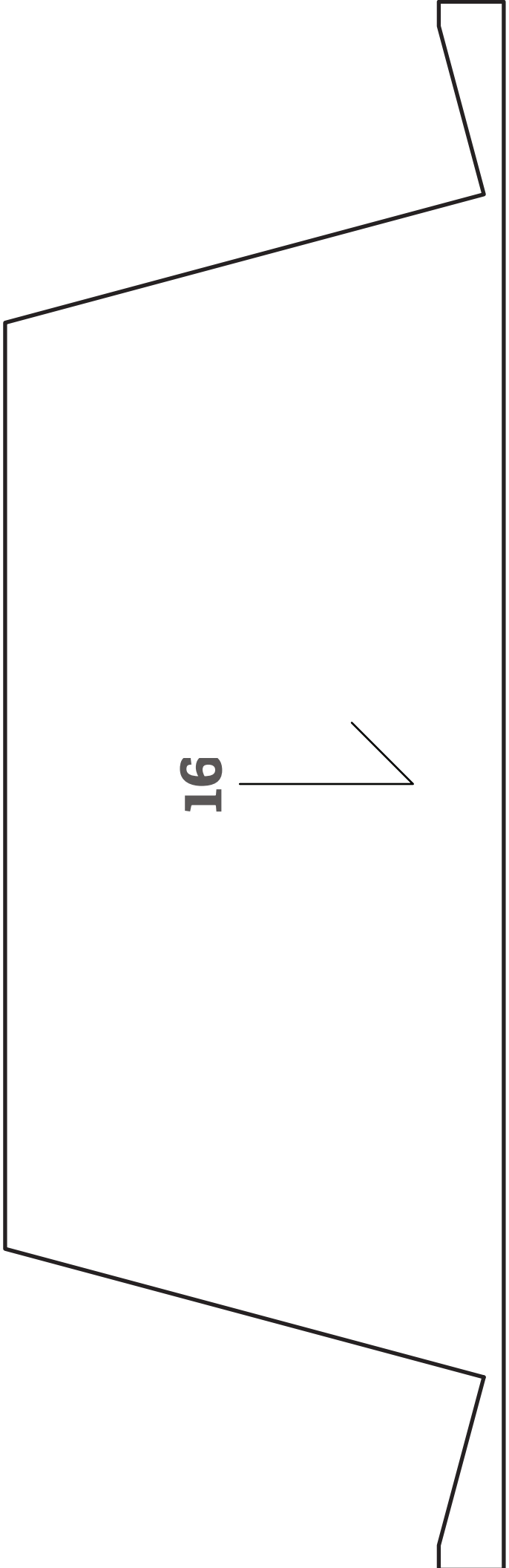
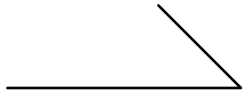

16

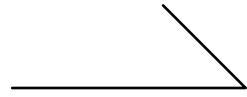

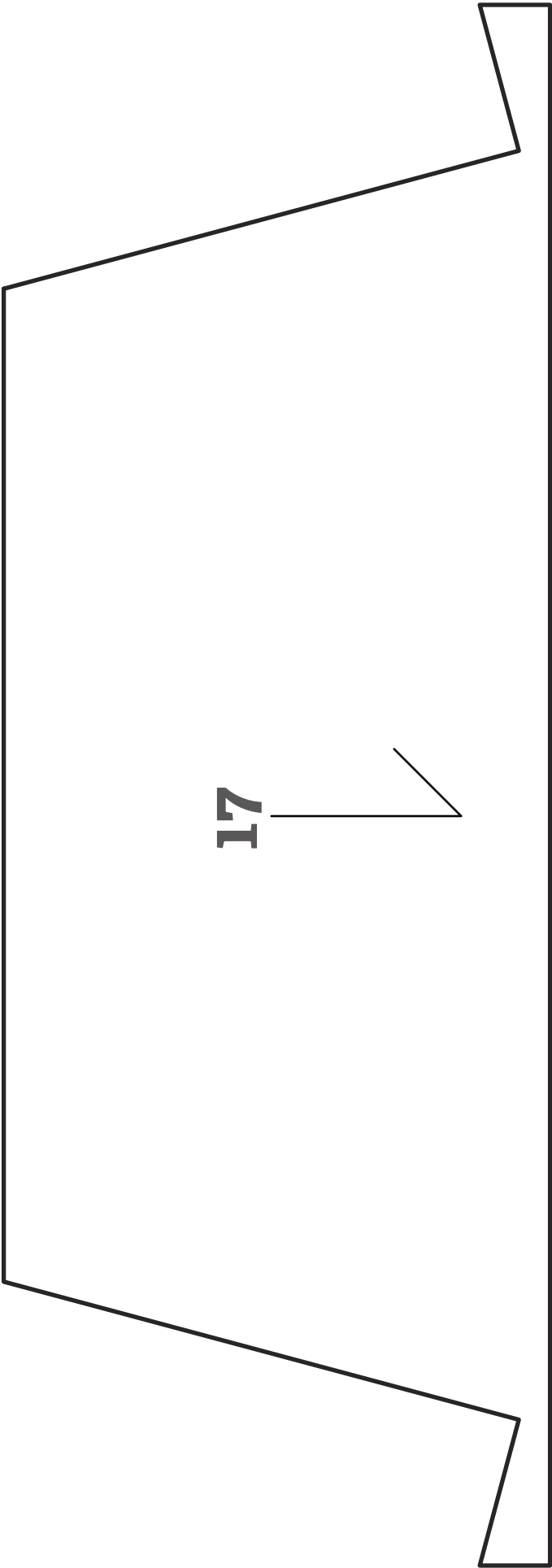

17

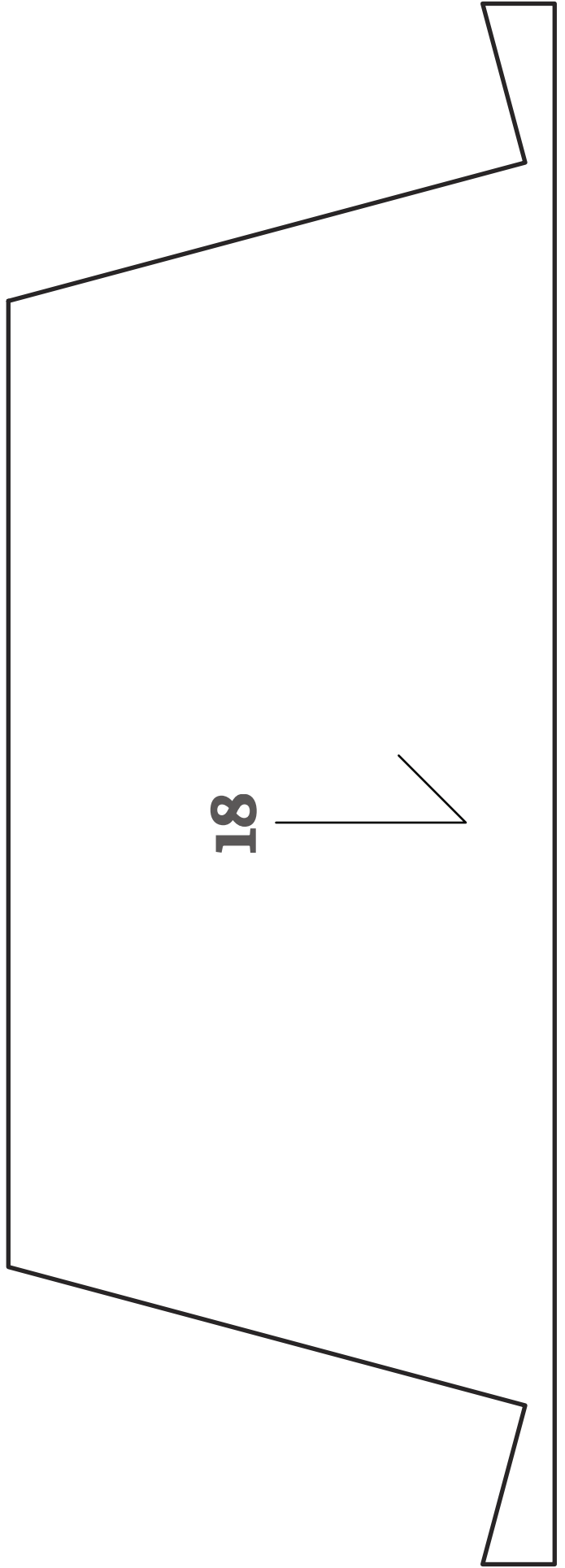

18

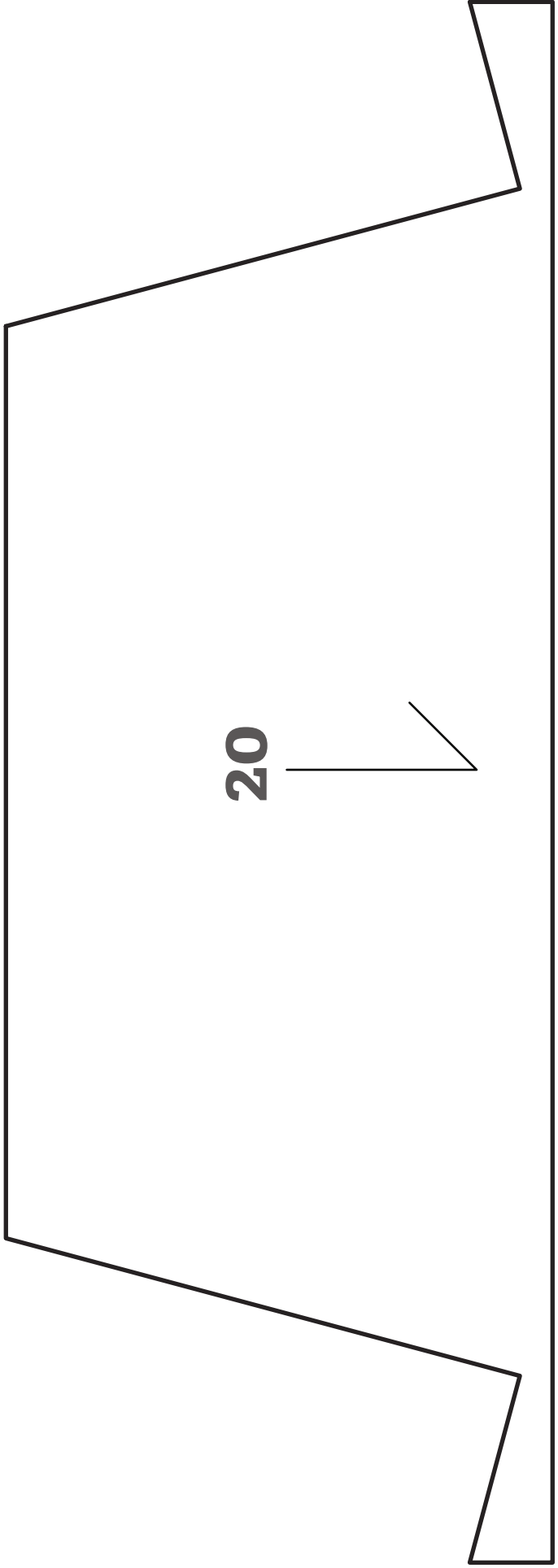
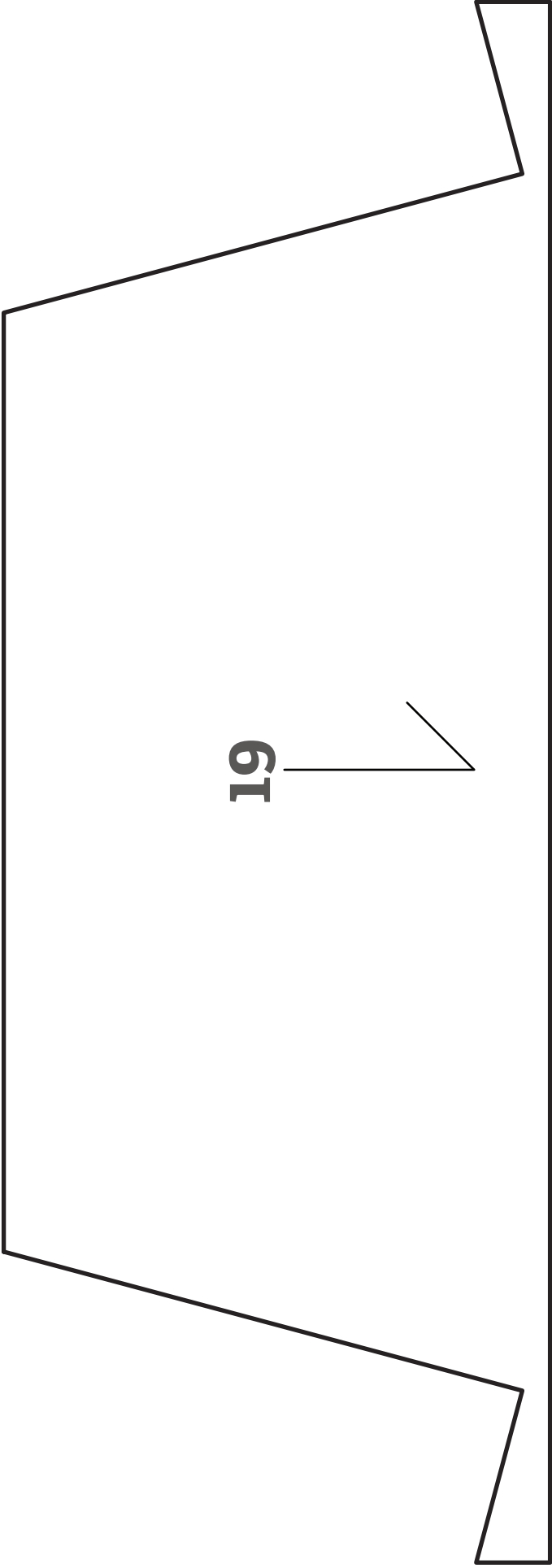

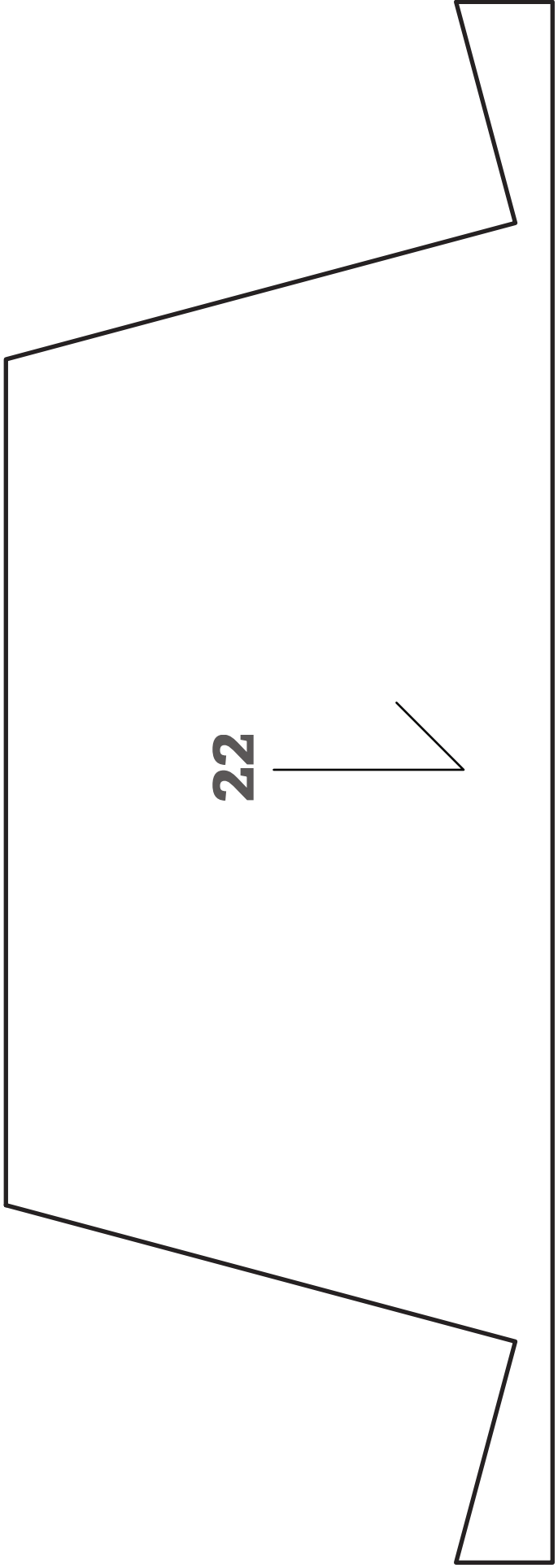
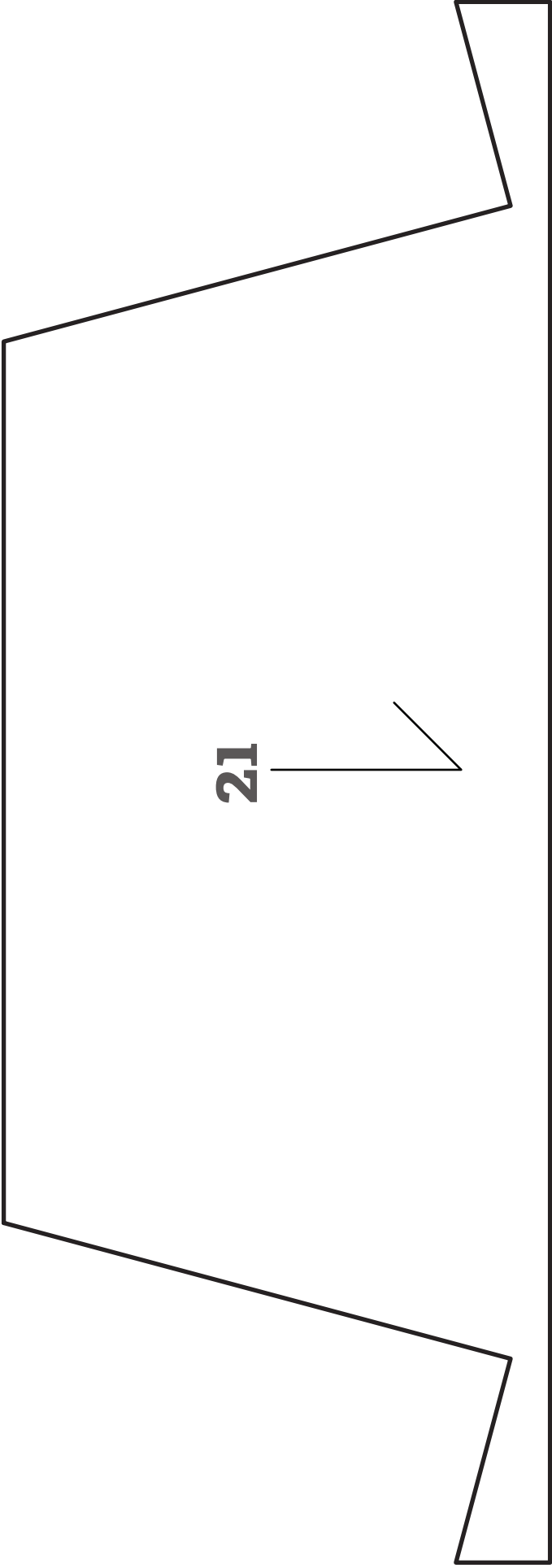

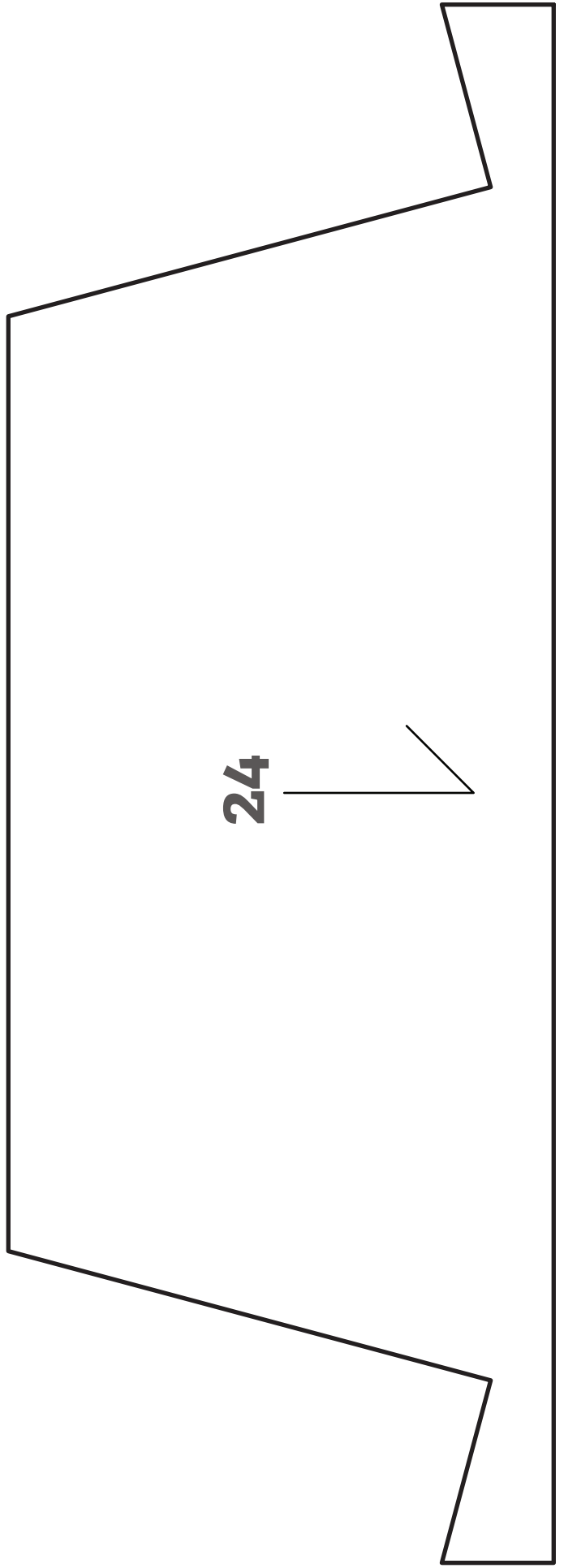
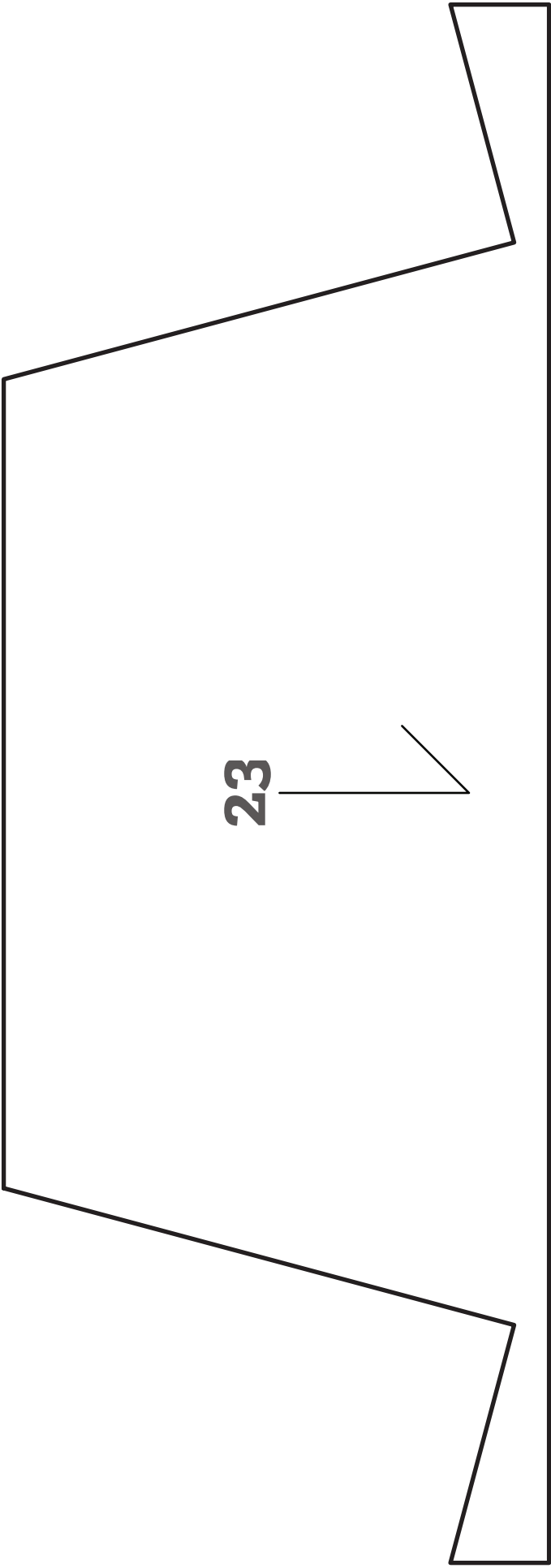

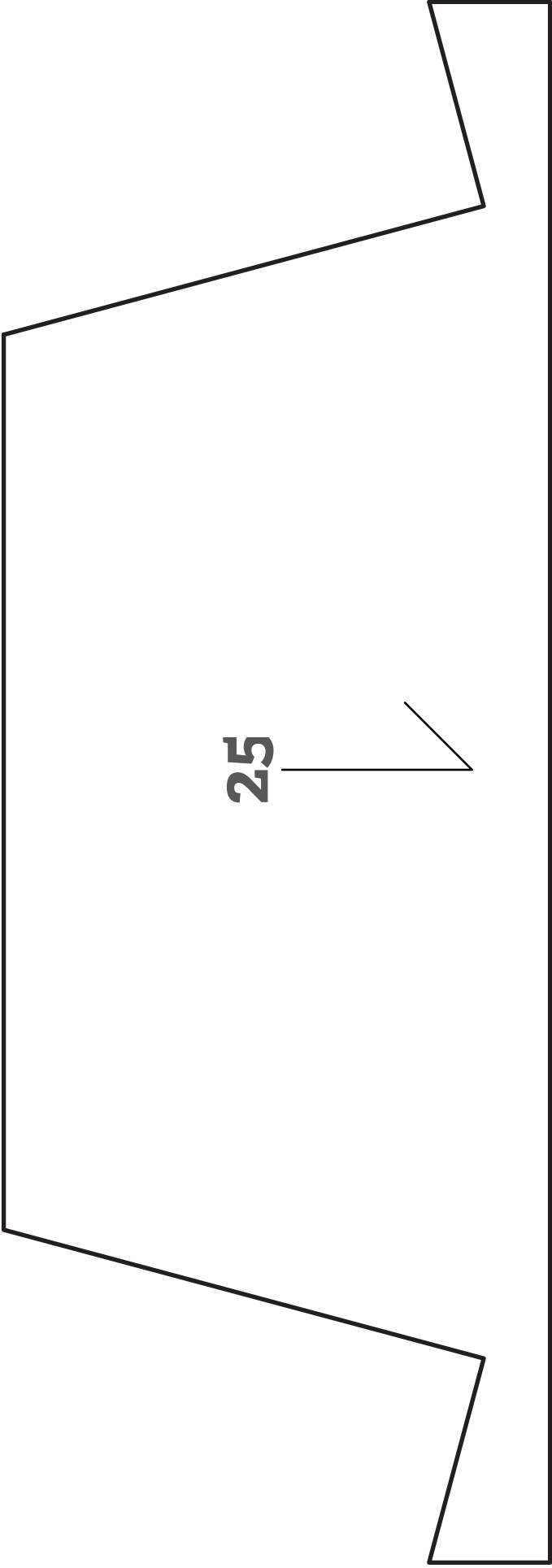

25

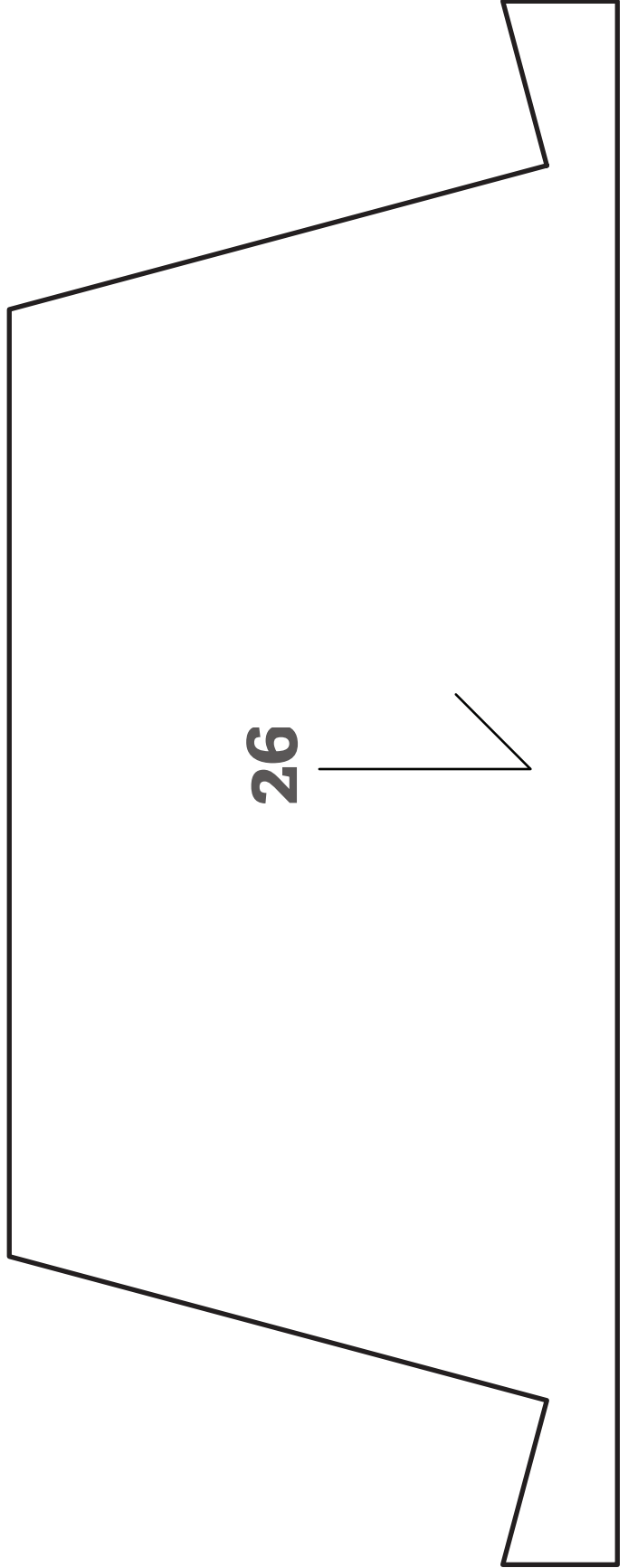

26

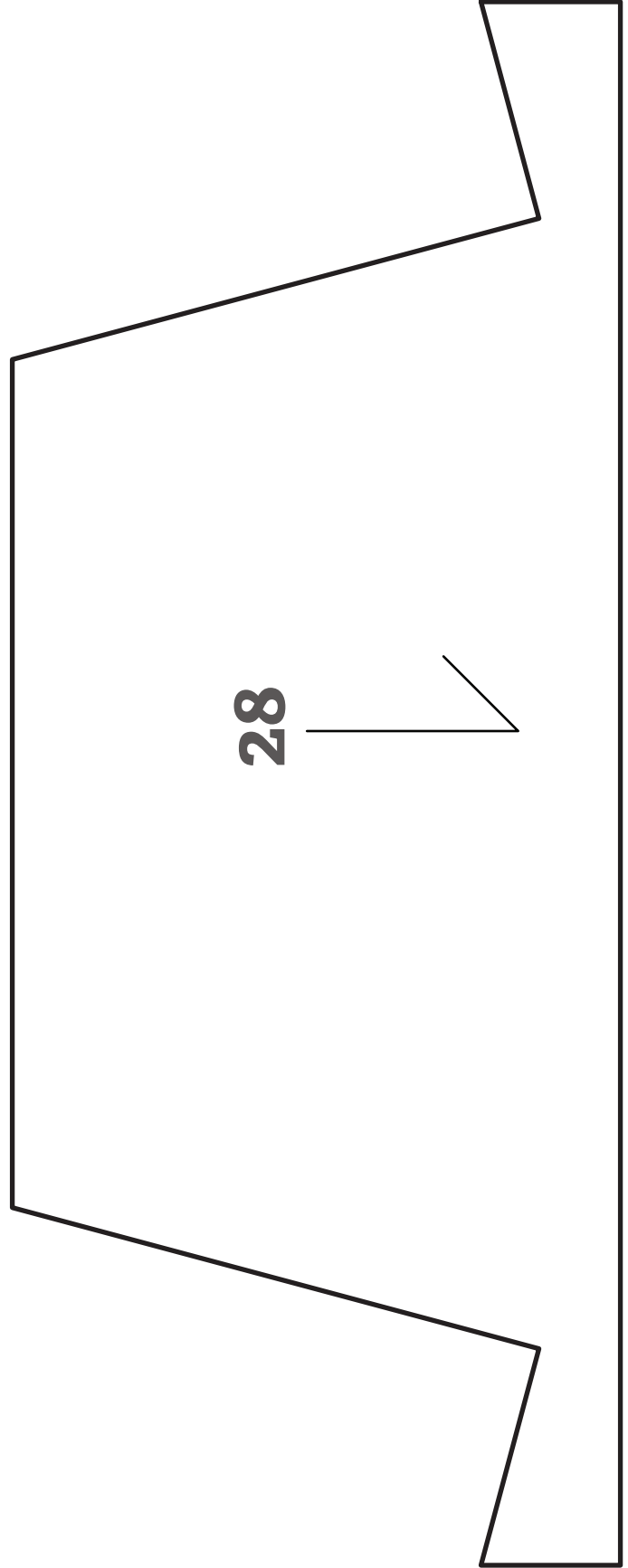
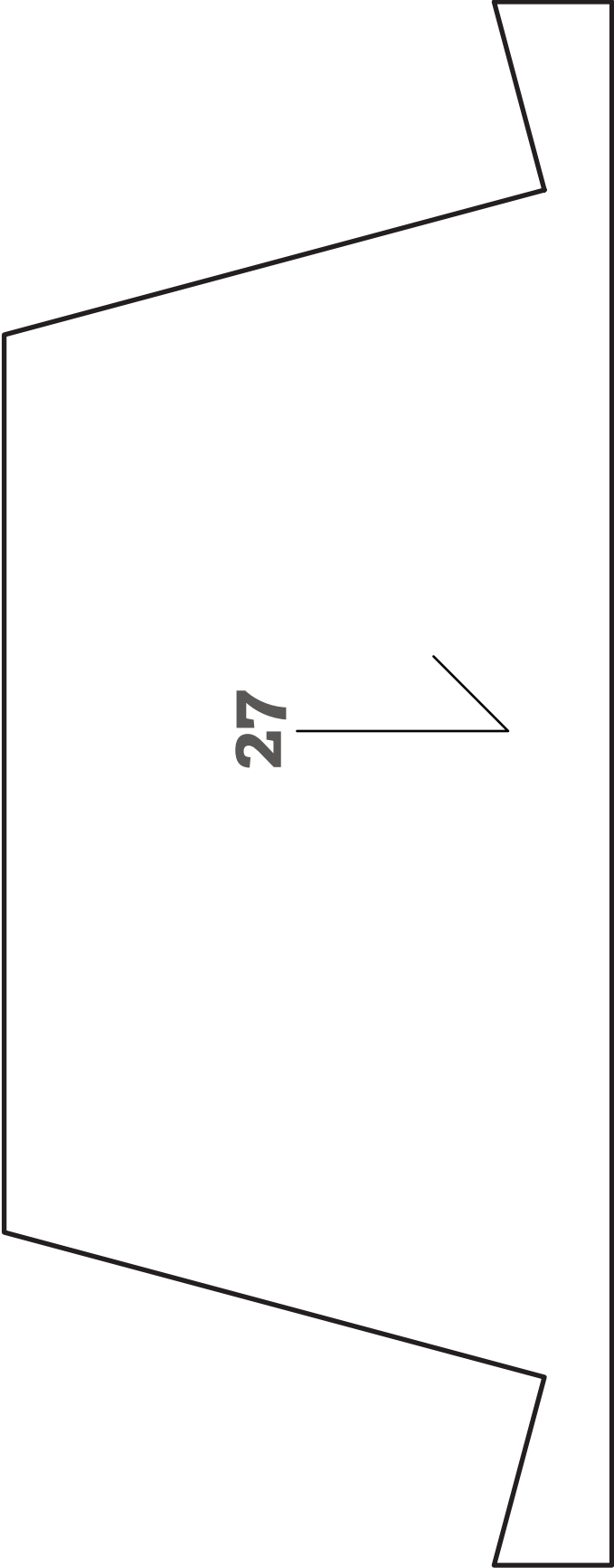

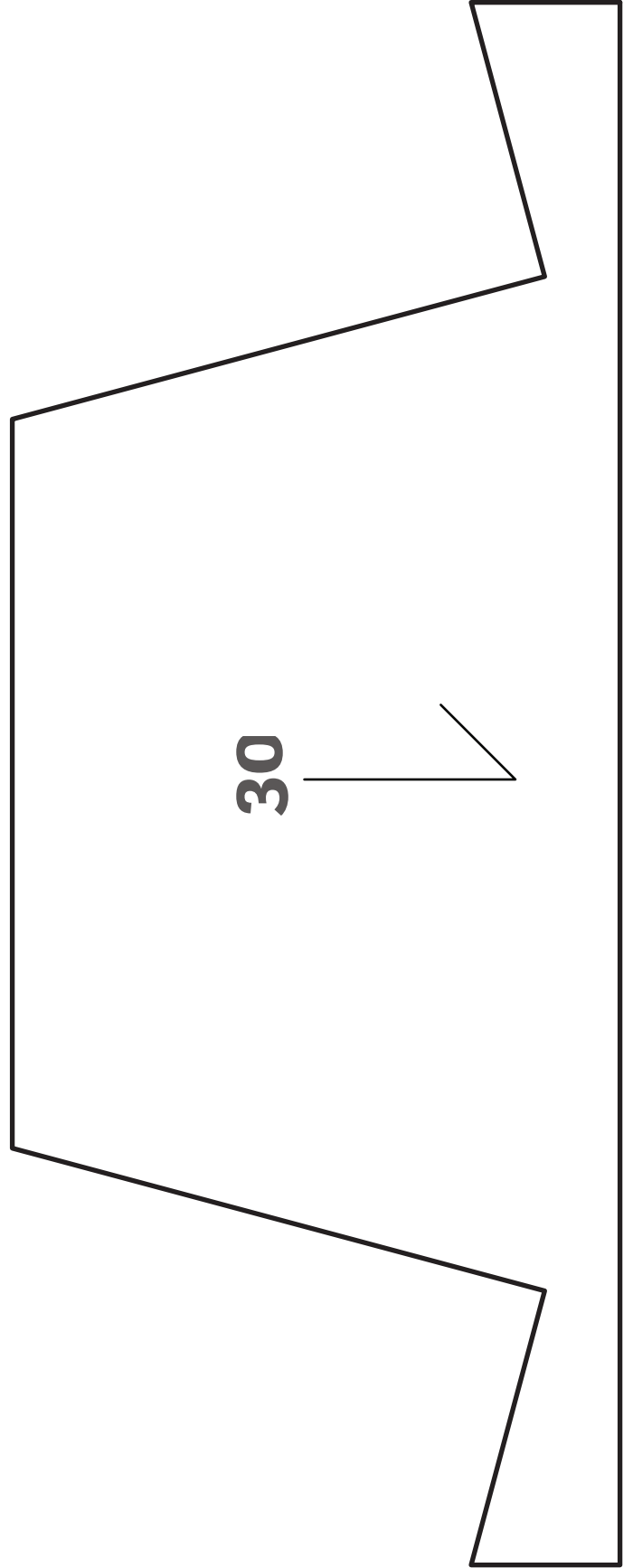
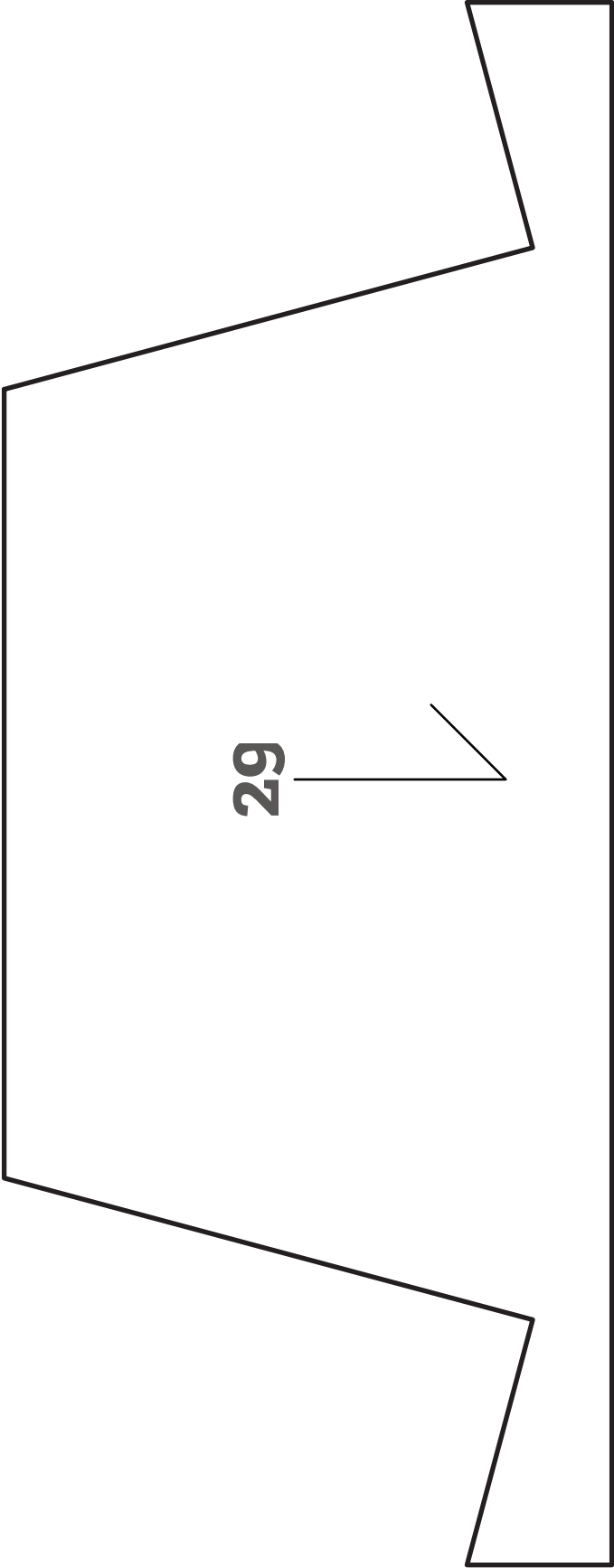

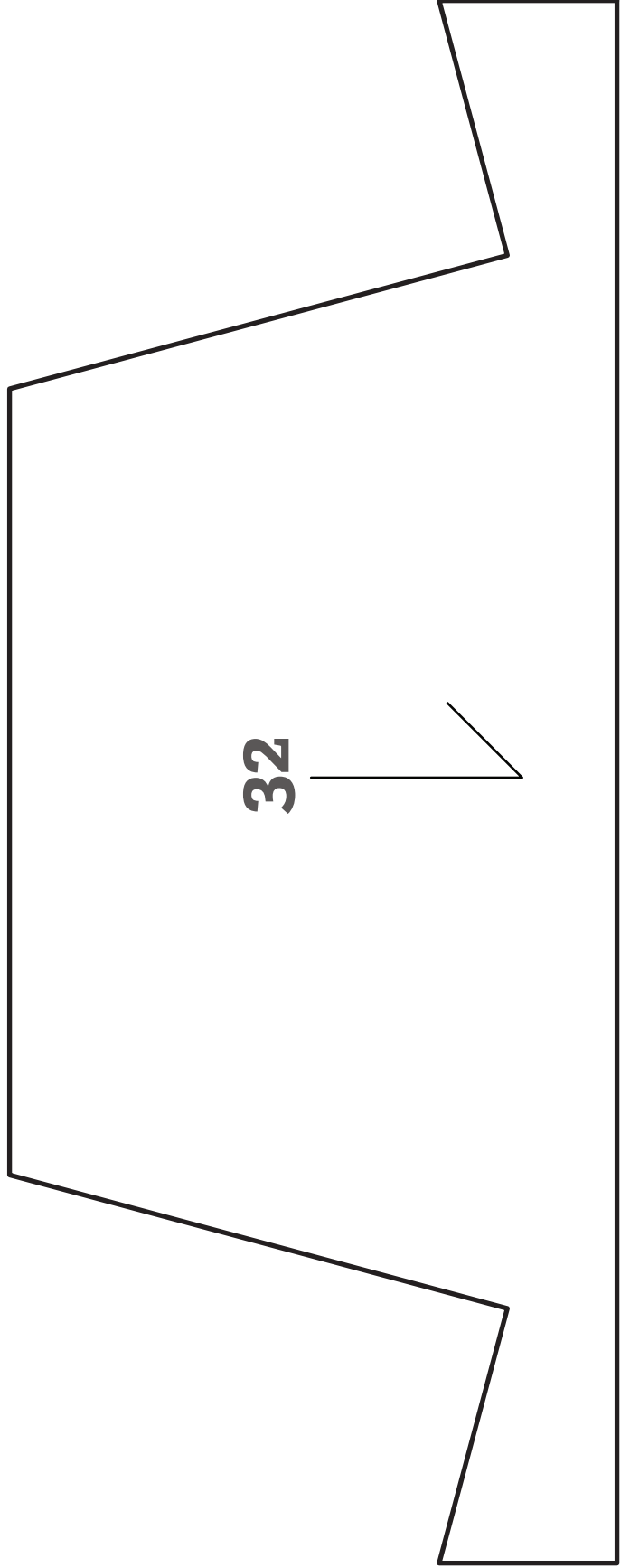
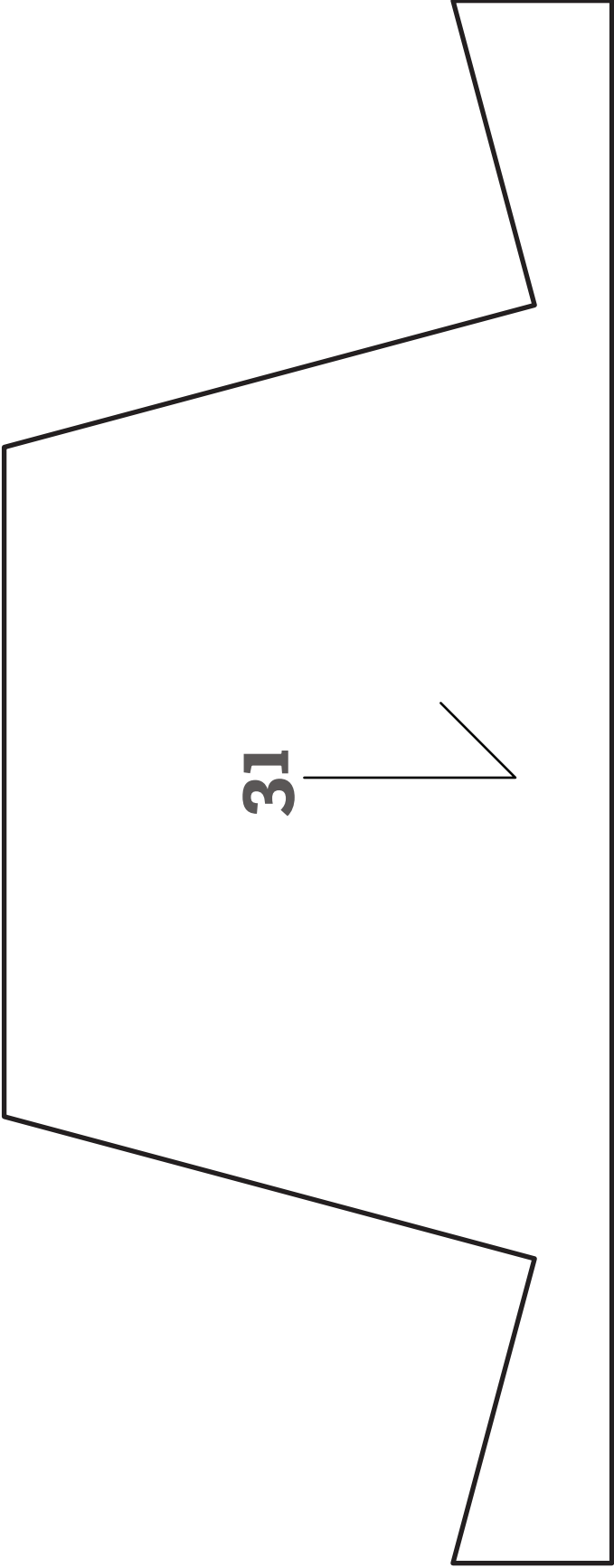

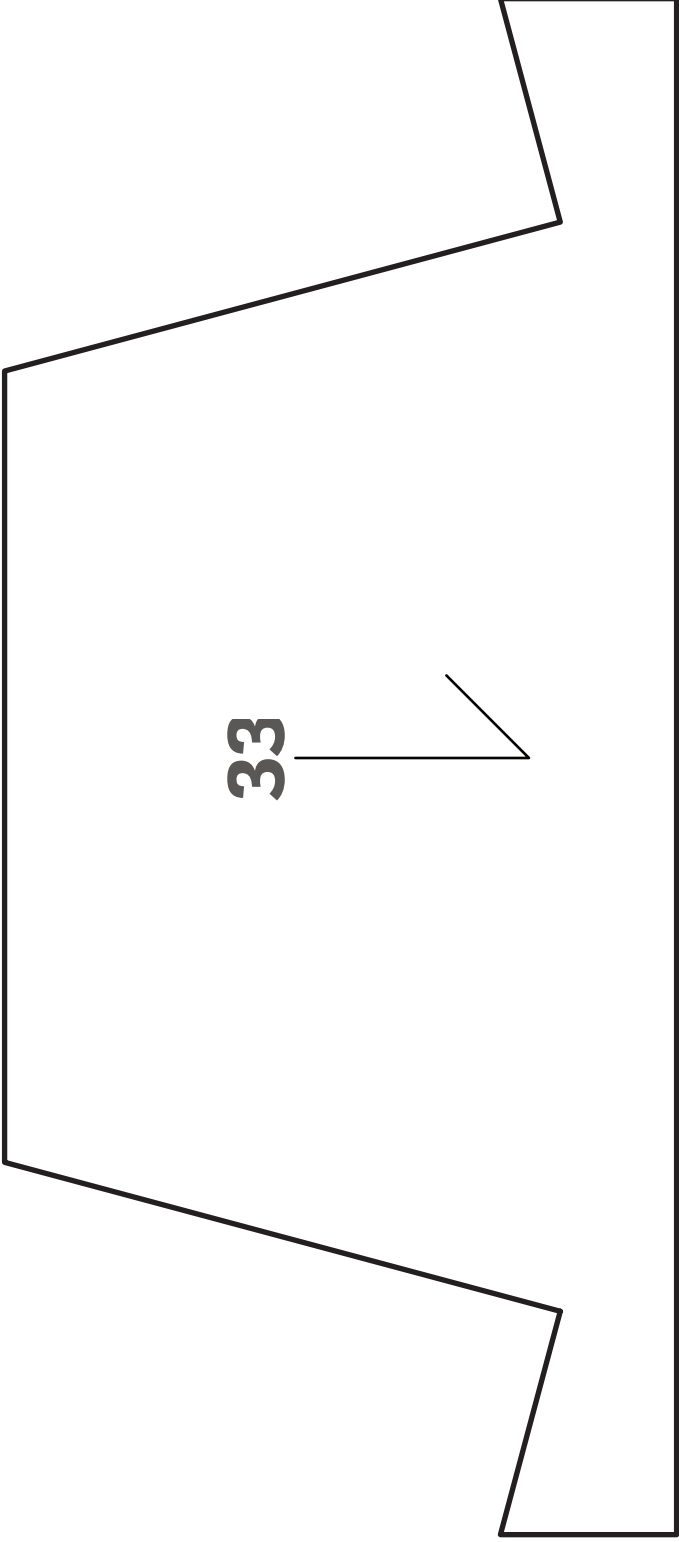

33

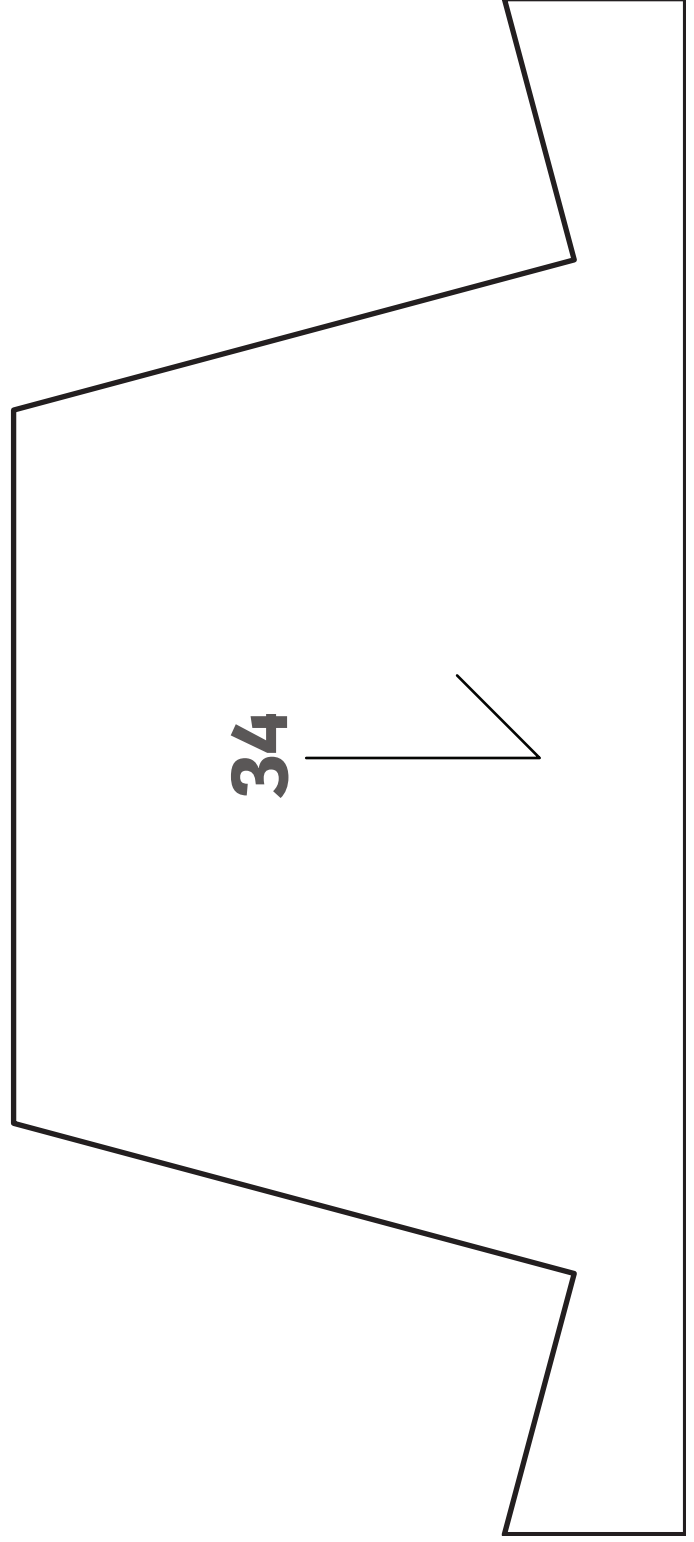

34

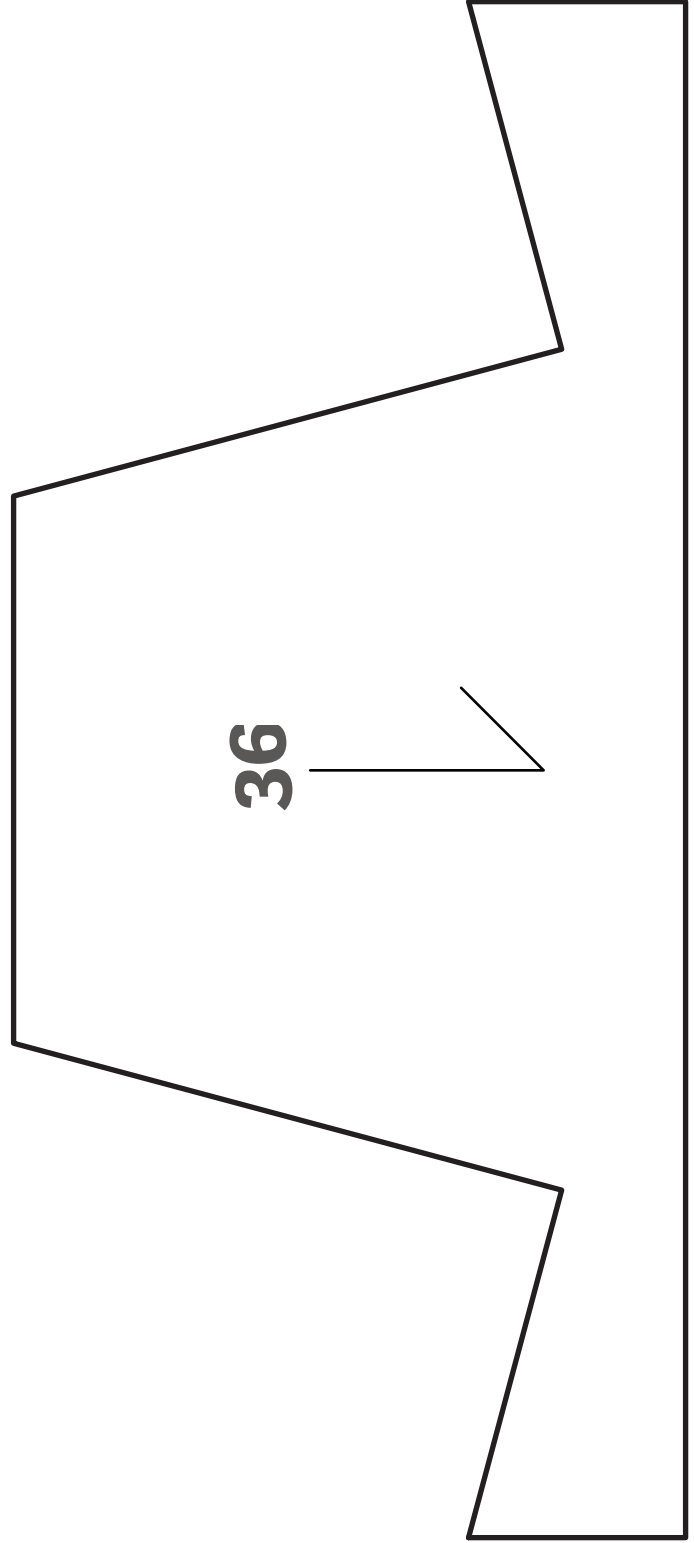
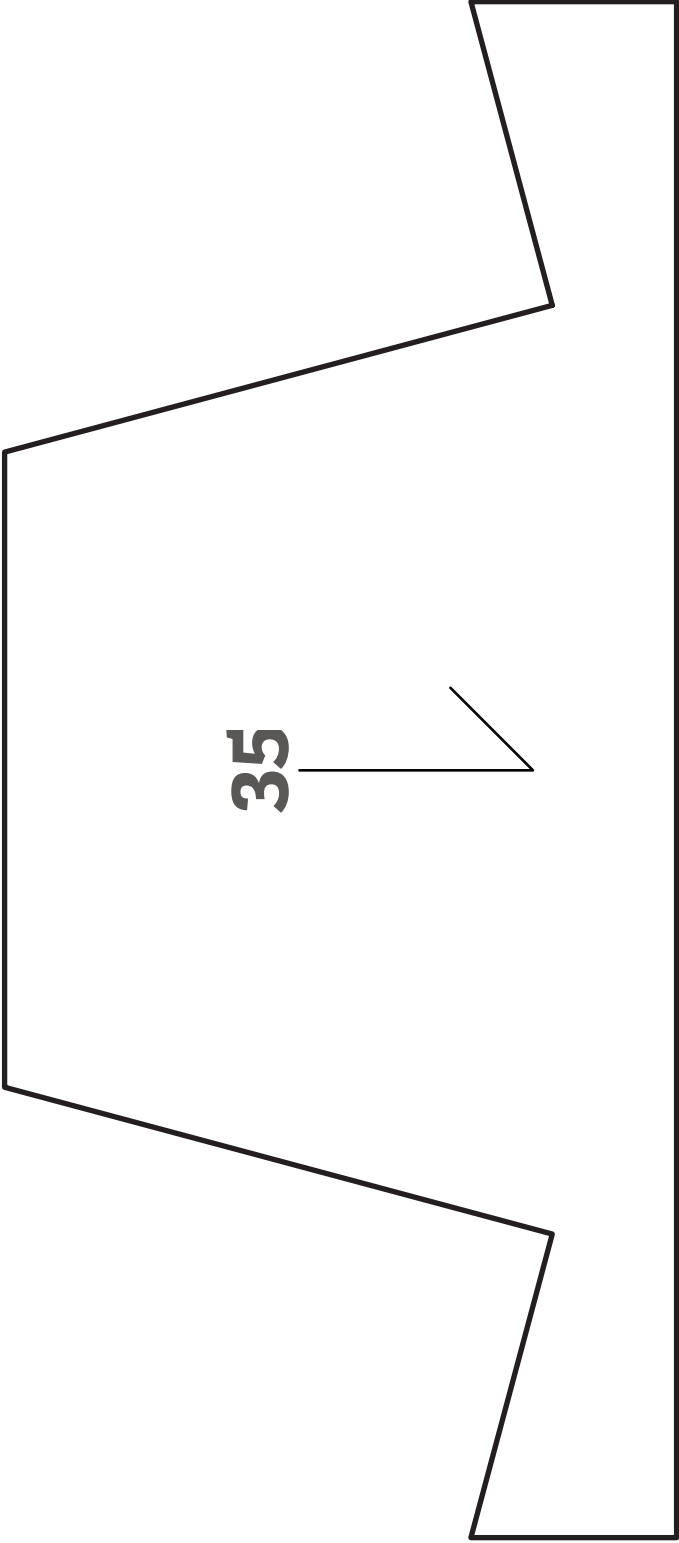

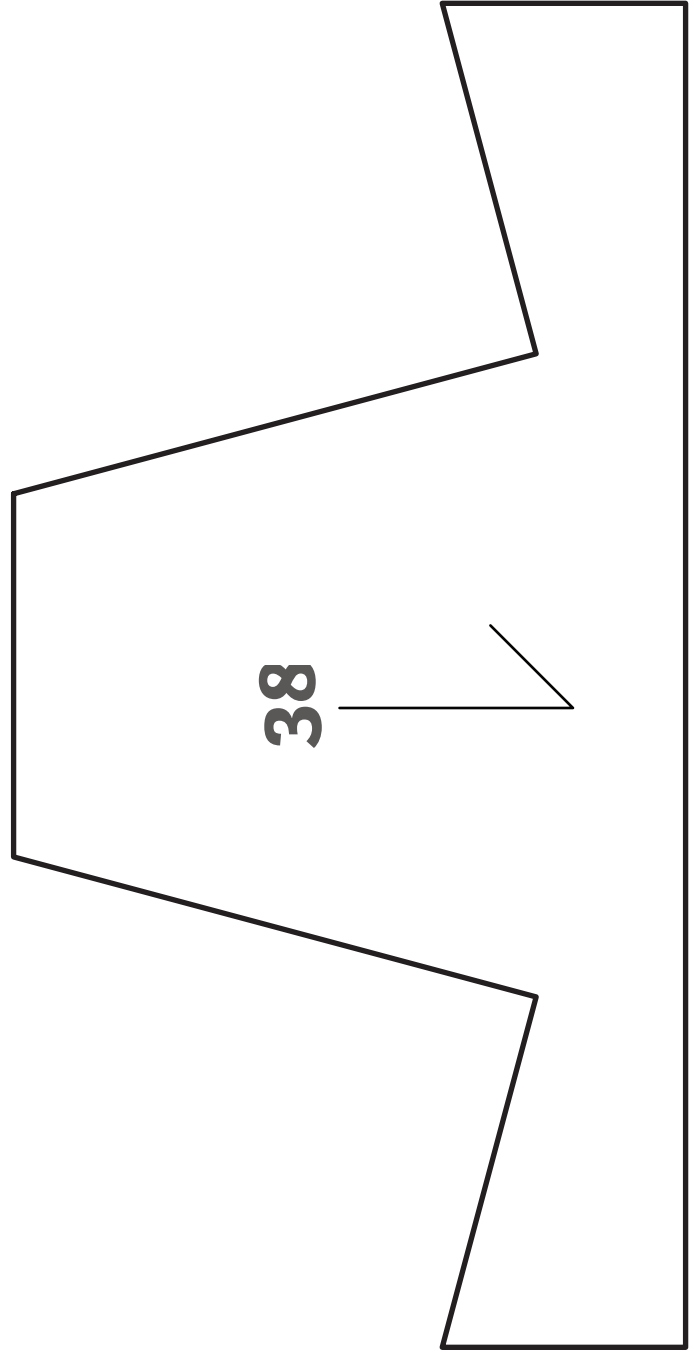
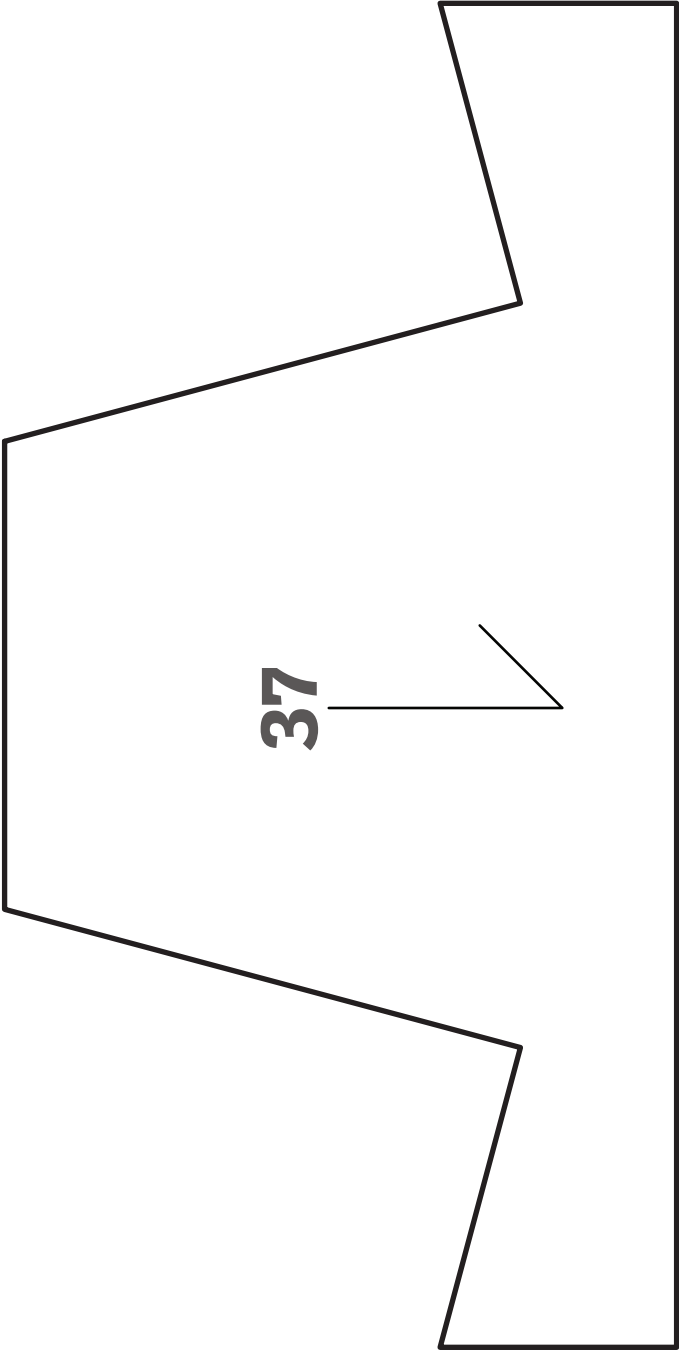

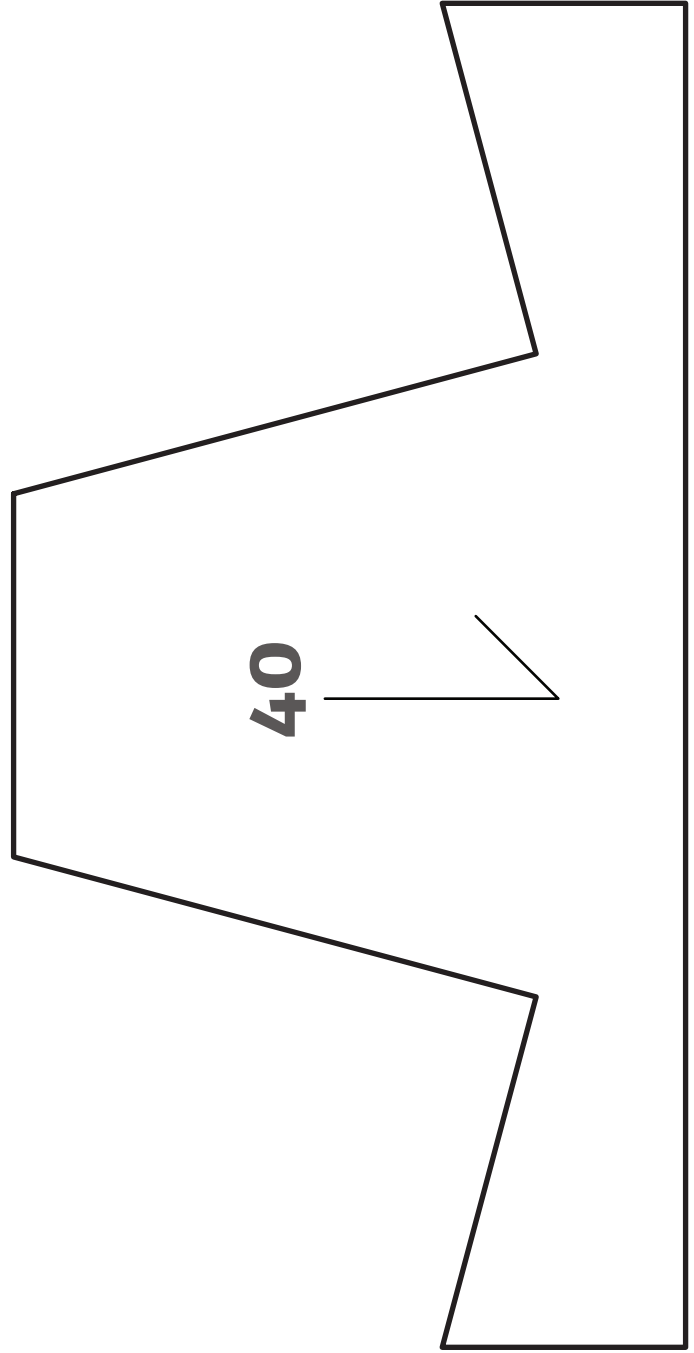
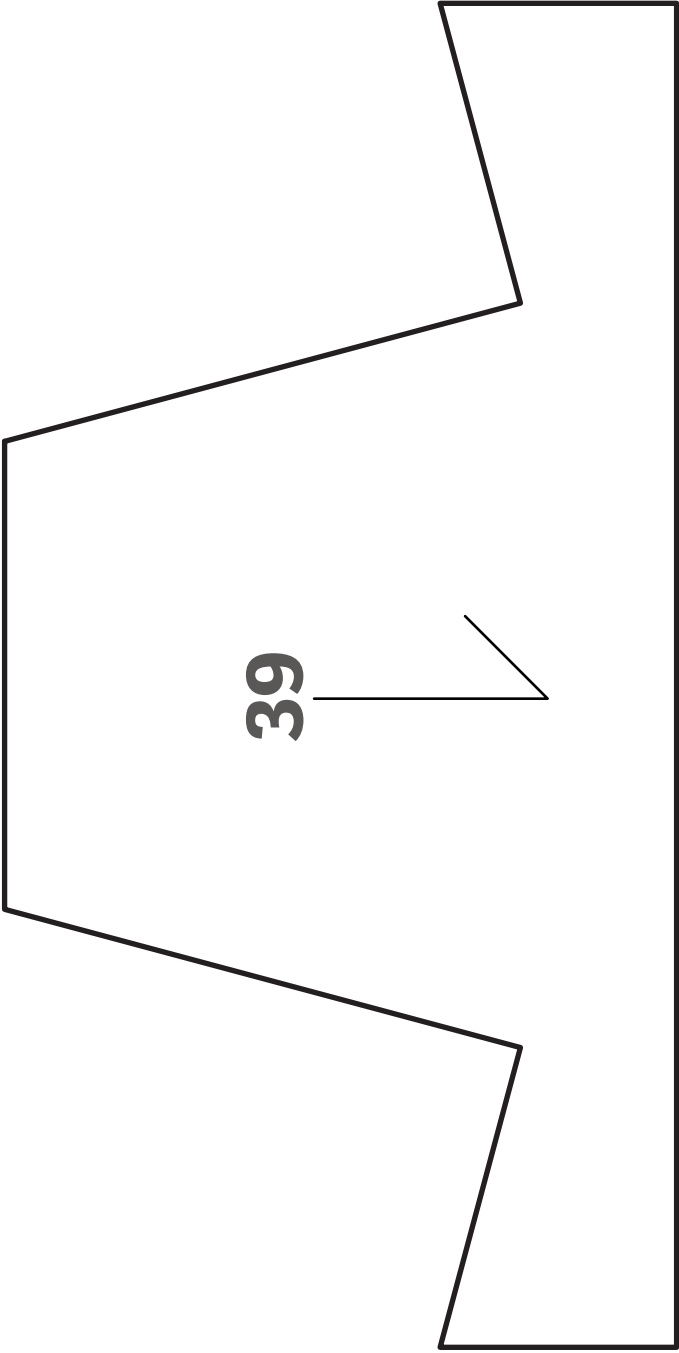

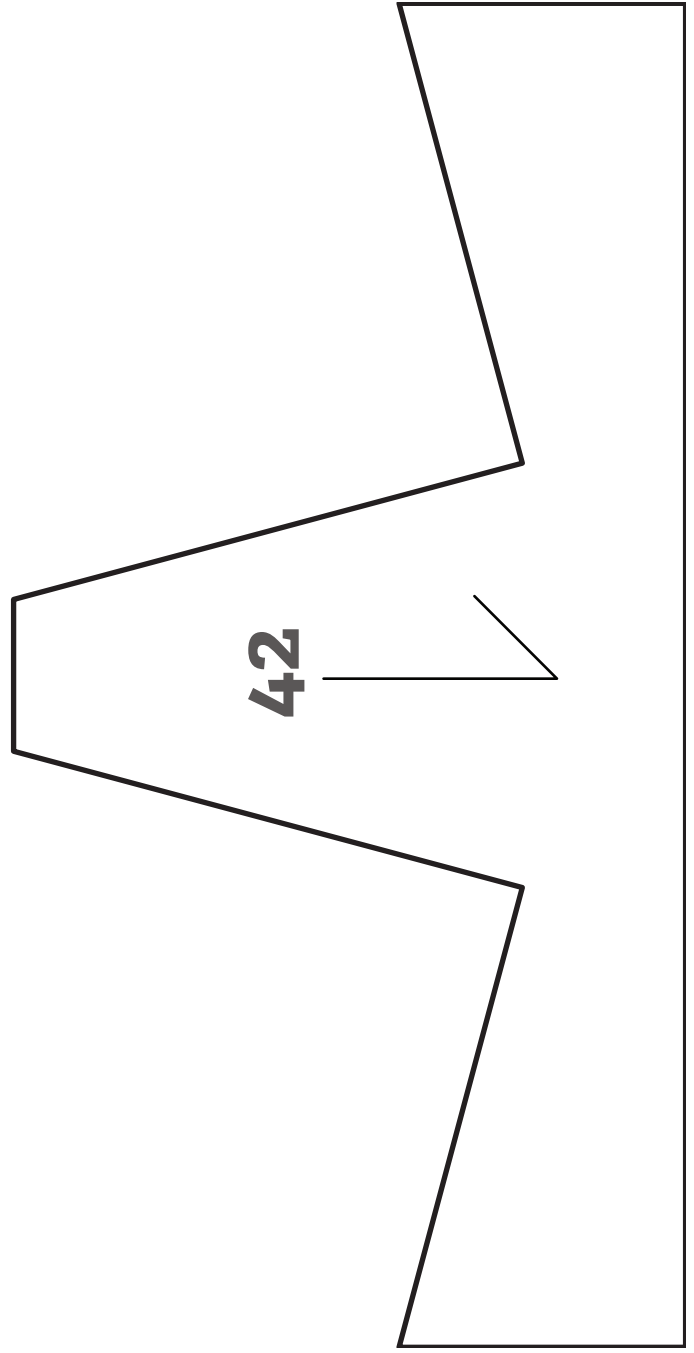
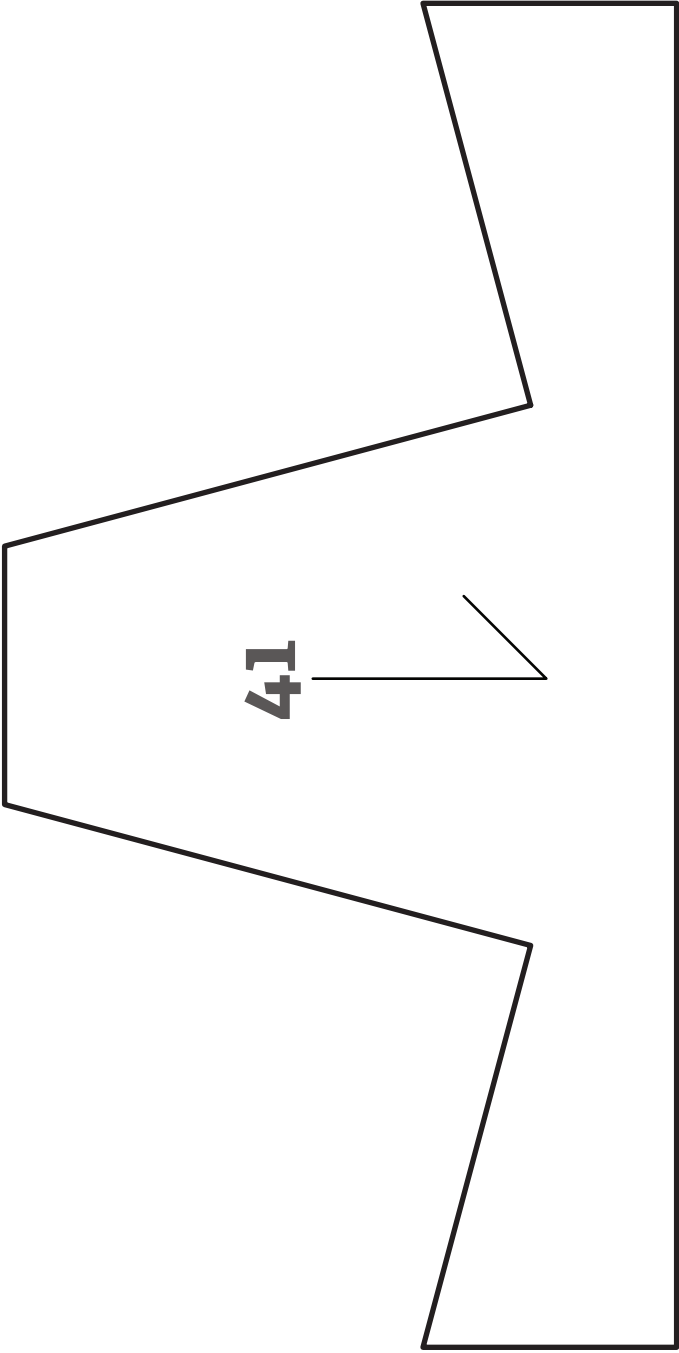

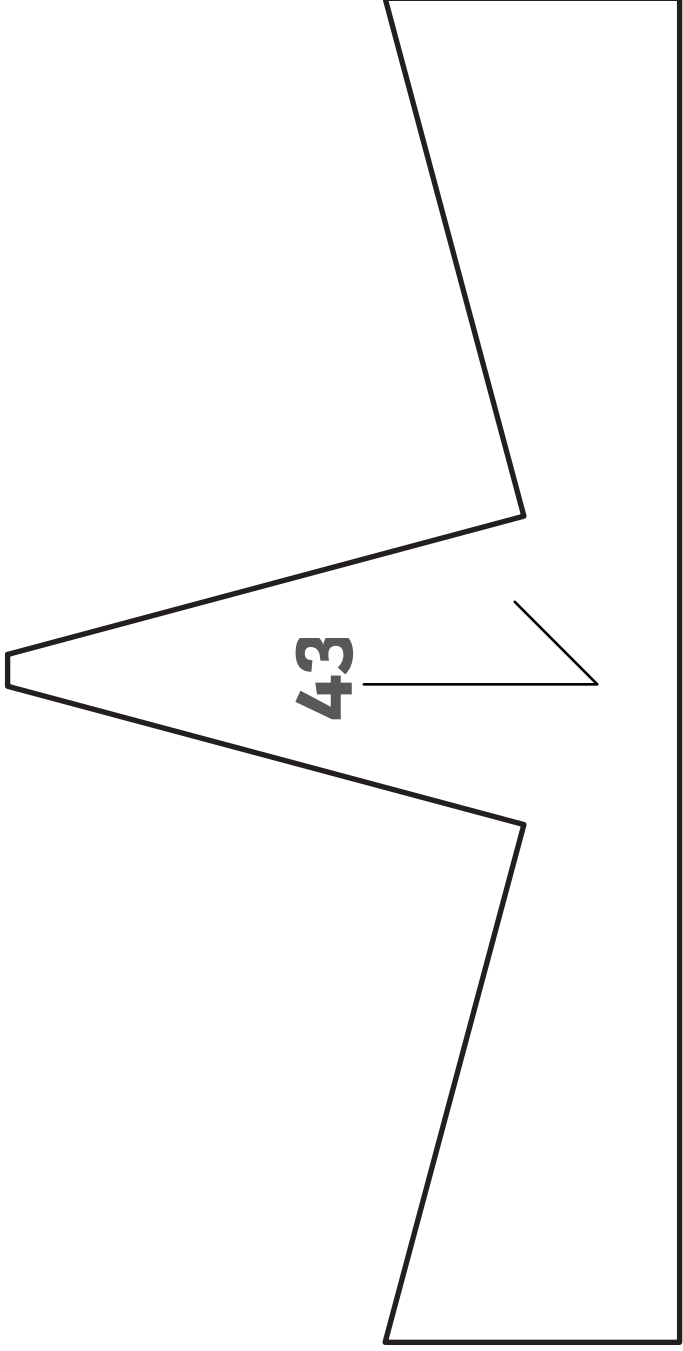

And We're Done!